

# CTZN NUMERICAL SENSOR

## User manual



## CONTENTS

<b>1. GENERAL .....</b>	<b>3</b>
<b>2. CHARACTERISTICS .....</b>	<b>4</b>
2.1 Technical characteristics. ....	4
2.2 CE compliance.....	5
<b>3. DESCRIPTION.....</b>	<b>6</b>
3.1 Product overview.....	6
3.2 Applications .....	6
3.3 Construction and dimensions.....	6
3.4 Communication.....	7
3.4.1 Modbus RTU registers.....	7
3.4.2 SDI12 frame.....	8
<b>4. INSTALLATION.....</b>	<b>8</b>
4.1 Sensor installation option .....	8
4.1.1 Accessories for immersion installation.....	8
4.1.2 Accessories for PVC pipe-mounting.....	10
4.1.3 Accessories for stainless steel pipe-mounting.....	11
4.3 Electrical connections.....	12
<b>5. STARTUP AND MAINTENANCE.....</b>	<b>13</b>
5.1 Initial startup.....	13
5.2 Calibration.....	13

## 1. General

In order to maintain and ensure the good working order of the CTZN sensor, users must comply with the safety precautions and warnings featured in this manual.

Assembly and activation:

- Assembly, electrical connection, activation, operation and maintenance of the measuring system must only be carried out by specialist personnel authorized by the user of the facilities.
- Trained personnel must be familiar with and comply with the instructions in this manual.
- Make sure the power supply complies with the specifications before connecting the device.
- A clearly-labeled power switch must be installed near the device.
- Check all connections before turning the power on.
- Do not attempt to use damaged equipment: it may represent a hazard and should be labeled as faulty.
- Repairs must only be carried out by the manufacturer or by AQUALABO's after-sales service department.

### ➤ Marking on the body of the sensor:

The marking on the body of the sensor indicates the serial number of the sensor (for the traceability) and the LOGO CE.



1	Datamatrix (contains the serial number)
2	<b>Serial number CTZN sensor : SN-PCTZX-YYYY</b> X : version YYYY : number
3	CE mark

## 2. Characteristics

### 2.1 Technical characteristics.

The technical characteristics can be modified without advance notice.

Measures	
Measure principle	Inductive conductivity sensor regulated in temperature
Measure ranges conductivity	0,0 –100,0 mS/cm
Resolution	0,1
Measure ranges salinity	5-60 g/Kg
Working temperature	0 to 50 °C
Temperature compensation	With NTC or external measure
Accuracy T°C	± 0.5 °C range 0-40 °C
Response time	90% of the value in less than 30 seconds
Storage temperature	-10°C à + 60°C
Maximum refreshing time	Maximum < 1 seconde

Sensor	
Dimensions	Diameter max. 62,4 mm, Lenght : 196 mm
Weight	700 g
Wetted Material	Body : EPDM, PVC, Stainless steel  Cable : polyurethane jacket Steam gland : Polyamide
Maximum pressure	5 bars
Connection	9 armoured connectors, polyurethane jacket, bare-wires or waterproof Fisher connector
Protection	IP68
Sensor cable	Standard : 3, 7 and 15 m (other length on request). 100 m Max. Up to 100 m with junction box.

Communication – Power supply									
Signal interface	Modbus RTU RS-485 and SDI-12								
Power requirements	5 to 28 volts, max 30 V								
Electric Consumption	<b>Automatic Standby &lt; 50 µA , Heating time 100 mS</b> <b>Average Modbus RS485/ Range 0-100 mS/cm</b> <table border="1" data-bbox="746 1294 1329 1357"> <thead> <tr> <th></th> <th>Vin 5V</th> <th>Vin 12 V</th> <th>Vin 24 V</th> </tr> </thead> <tbody> <tr> <td>1 measure/s</td> <td>31 mA</td> <td>15,5 mA</td> <td>11,5 mA</td> </tr> </tbody> </table> Max current pulse 700 mA during 2 mS, 350 mA during 150 mS		Vin 5V	Vin 12 V	Vin 24 V	1 measure/s	31 mA	15,5 mA	11,5 mA
	Vin 5V	Vin 12 V	Vin 24 V						
1 measure/s	31 mA	15,5 mA	11,5 mA						

## 2.2 CE compliance.

Pursuant to the article 11 of the directive 89 / 336 / EEC relative to the electromagnetic compatibility.

We declare that the digital sensor of the range DIGISENS sensor CTZN was tested and declared in compliance with the European standards :

### **Standard tests : EN 61326-1 edition 2013**

**Emission** - EMC EN 55022 Class B

**Immunity** - EN 61000-4-3 A

EN 61000-4-2 B

EN 61000-4-6 A

EN 61000-4-4 B

**Shone disturbances** : EN 55011B

**Identification of the measurement process** : composed of :

1- one probe

2- Ponsel's cable.

EN 61000-4-5 Not concerned for sensors with a cable lower or equal to 30 M

**Commercial name** : DIGISENS range

**Manufacturer:**

AQUALABO  
90 Rue du professeur P. Milliez  
94506 CHAMPIGNY-SUR-MARNE

**Responsible UE :**

AQUALABO  
90 Rue du professeur P. Milliez  
94506 CHAMPIGNY-SUR-MARNE

### 3. Description.

#### 3.1 Product overview

Inductive method :

A ring-type coil is excited at fixed intervals and the response is retrieved on a second coil, which is linked to the excited coil. The connectivity between the coils (determined by the degree of conductivity) takes place via the conducting solution.

Economic and successful technology that requiring not enough maintenance and not consumable.

The CTZN sensor offers the following advantages:

- Low operating costs due to reduced maintenance work (no electrolyte changes)
- Greater calibration intervals due to low drift behaviour
- No polarization voltage required • High measuring accuracy, even for low concentrations • Rapid response times

The sensor features excellent interference immunity thanks to the integrated preamplifier and digital signal processing. The measured value for conductivity is automatically compensated with the temperature and transferred without interference to the connected display unit and controller via a digital interface. The sensor also includes a log book containing the last ten successful calibrations in the form of a ring buffer.

#### 3.2 Applications

The compact and robust sensor is particularly well suited to the following typical areas of application:

- Urban wastewater treatment
- Industrial effluent treatment
- Sea water
- Fish farming

#### 3.3 Construction and dimensions.

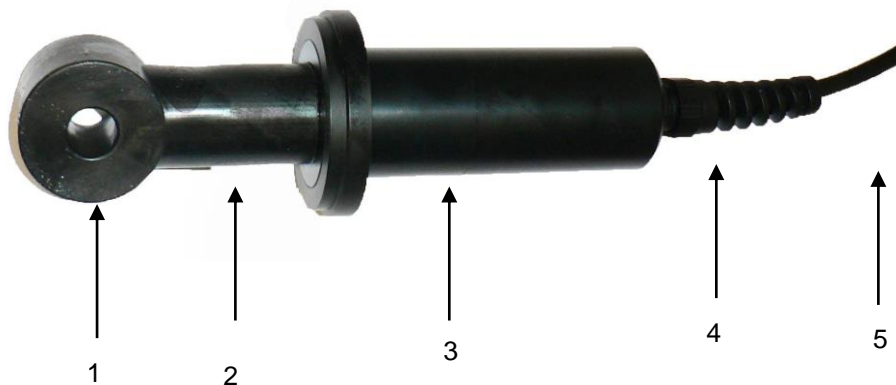

- (1) NTC Temperature sensor
- (2) EPDM Head of body
- (3) PVC Sensor body with measurement electronics
- (4) Cable bushing
- (5) Securely connected connection cable

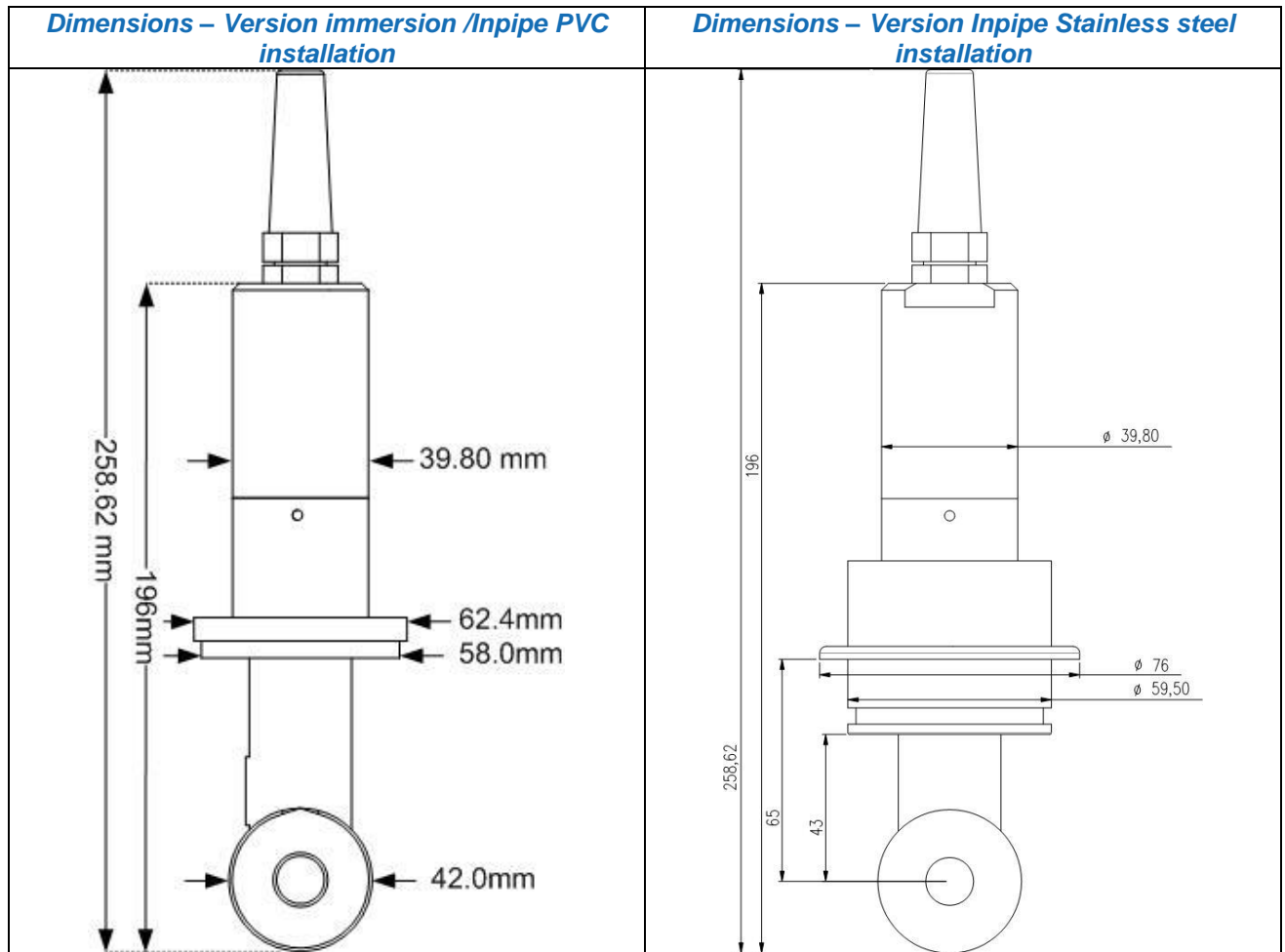

### 3.4 Communication.

#### 3.4.1 Modbus RTU registers.

The link protocol must correspond to MODBUS RTU.

See document:

- Modbus\_over\_serial\_line\_V1\_02.pdf
- Modbus\_Application\_Protocol\_V1\_1a.pdf
- Modbus memory for PONSEL digital Sensors :  
*SENSOR\_TramesCom\_xxx\_UK.xls*

The Modbus memory plane is identical for each parameter of the Sensors.

The Modbus protocol for the Sensors allows you to measure the parameter (+ temperature) of the Sensor and to calibrate the parameter (+ temperature). Furthermore, there are certain numbers of functions such as:

- Select the averaging value
- Read the Sensor description
- Return to default coefficients
- Modify the Sensor address
- Information on measures conducted (Out Of Specification measures, measures in progress, etc.).
- Date and name of the operator who performed the calibration
- etc.

To have more information on the open PONSEL's Modbus protocol please consult the last version of the following documents :

- the pdf file : Modbus\_SpecificationsVxxx-EN
- the excel file : Digital sensor Frame\_XXX\_UK

### 3.4.2 SDI12 frame.

A list of SDI12 registers is available for network communication.

Please ask to our hotline service the documentation on SDI12 communication.

## 4. Installation.

### 4.1 Sensor installation option

For the installation of the sensors in condition of immersion or in-pipe insertion, we advise to use accessories adapted and proposed by AQUALABO.

#### 4.1.1 Accessories for immersion installation.

In immersion condition, it is necessary to maintain the sensor by the body and not to leave the sensor suspended by the cable at the risk of damaging the sensor.

AQUALABO proposes a range or pole (long version) in order to install the sensor in open basins. It can be positioned a considerable distance from the basin edge with the bracket suspended for example.

Please note the following when planning your set-up:

- The fitting must be easily accessible to allow the sensor or the fitting itself to be maintained and cleaned regularly
- Do not allow the fitting (and thus also the sensor) to swing against and hit the basin edge
- When working with systems involving pressure and/or temperature, ensure that the fitting and sensor meet all relevant requirements
- The system designer must check that the materials in the fitting and sensor are suitable for the measurement (chemical compatibility, for instance)

<b>Material</b>	PVC
<b>Admissible temperature</b>	0 to 60 °C
<b>Pressure max.</b>	5 bars



➤ **Long pole**

The long poles are available in elbow version, for installations in aeration basin, and straight, for applications in open channel. Every pole is equipped with an elbowed shutter and with waterproofness joints. The lower part includes a nozzle which is adapted to the sensor what assures its mechanical support.

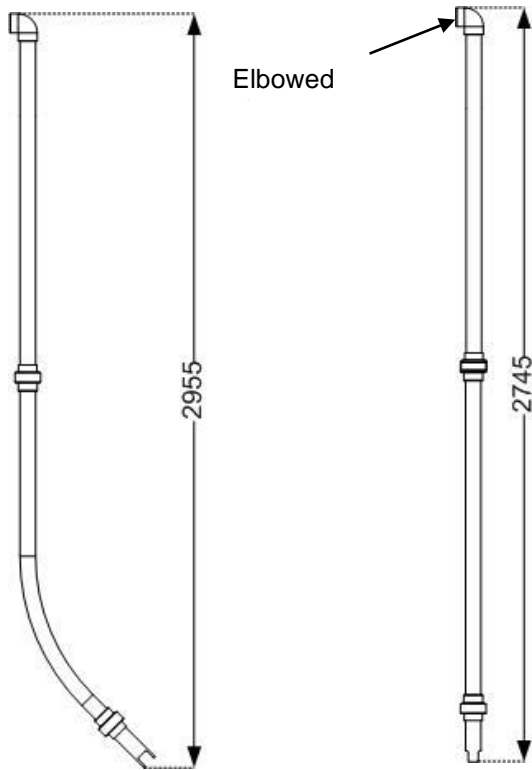

- **Elbowed pole with elbowed shutter**

PF-ACC-C-00109	90° ELBOW LONG POLE FOR CTZN SENSOR (2955 mm, ELBOWED SHUTTER)
----------------	--

- **Straight long pole with elbowed shutter**

PF-ACC-C-00115	STRAIGHT LONG POLE FOR CTZN SENSOR (2745 mm, ELBOWED SHUTTER)
----------------	---

➤ **Mounting accessories for pole.**

The elements of fixation for the poles are flexible and specially studied to adapt themselves to the different configurations of assembly.

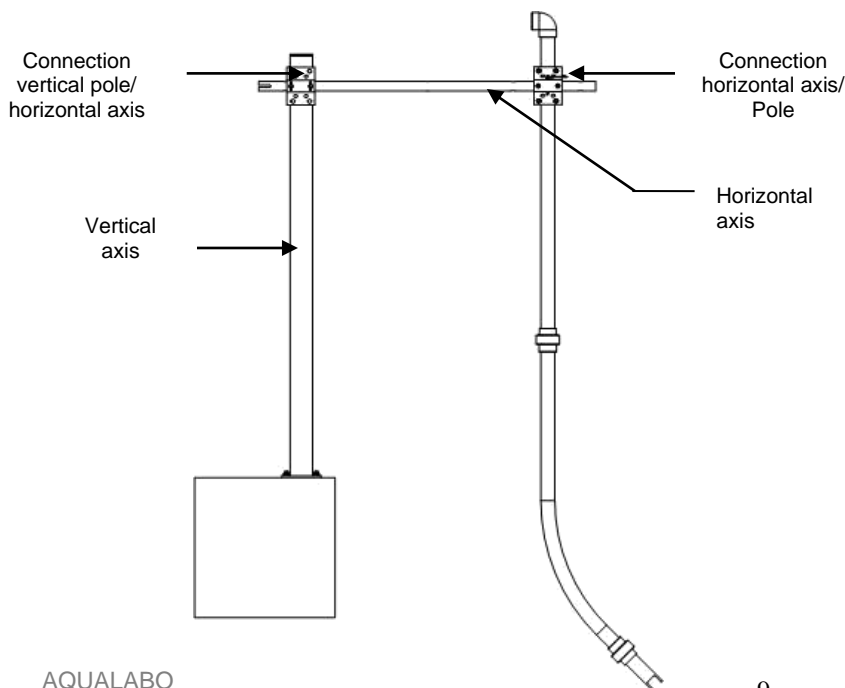

- **Pole kit fixation**

NC-ACC-C-00009	POLE FIXATION KIT FOR NUMERICAL SENSOR (ON LOW WALL)
NC-ACC-C-00010	POLE FIXATION KIT FOR NUMERICAL SENSOR (ON LIFE LINE)
NC-ACC-C-00011	POLE FIXATION KIT FOR NUMERICAL SENSOR (ON VERTICAL AXIS)
PF-ACC-C-00272	VERTICAL AXIS FOR NUMERICAL SENSOR POLE (TO BE FIXED ON SOIL)

#### 4.1.2 Accessories for PVC pipe-mounting.

Every system of assembly is delivered with an adapter (and the appropriate joints) and one T of assembly (90 ° for CTZN sensor) to stick on a 90 mm diameter pipe. Its special design type ensures the correct inflow to the sensor, thus preventing incorrect measurements.

Please note the following when planning your piping set-up:

- The fitting must be easily accessible to allow the sensor or the fitting itself to be maintained and cleaned regularly
- We recommend bypass measurements. It must be possible to remove the sensor through the use of shut-off valves
- When working with systems involving pressure and/or temperature, ensure that the fitting and sensor meet all relevant requirements
- The system designer must check that the materials in the fitting and sensor are suitable for the measurement (chemical compatibility, for instance)

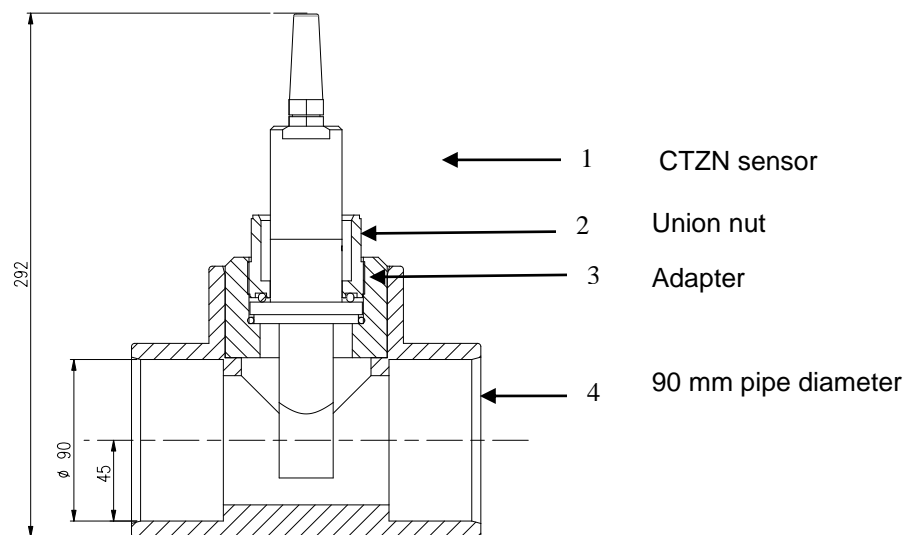

Mounting system for CTZN sensor (**PF-ACC-M-00001**)

- 1 Unscrew the union nut (2) from the PVC flow fitting (3).
- 2 Guide the sensor cable through the union nut on the fitting.
- 3 Insert the sensor (1) into the fitting as far as the position shown in the middle image above.
- 4 Screw the union nut onto the fitting as far as the stop.

#### 4.1.3 Accessories for stainless steel pipe-mounting.

The accessories of assembly for stainless pipe are proposed with an adapter and its joints with or without the systems of clamp / Nipple. The acceptable maximum pressure for the sensors is 5 bars.

The system of assembly can be delivered with or without stainless steel clamp.

The adapter is compatible with a 90 mm diameter external clamp.

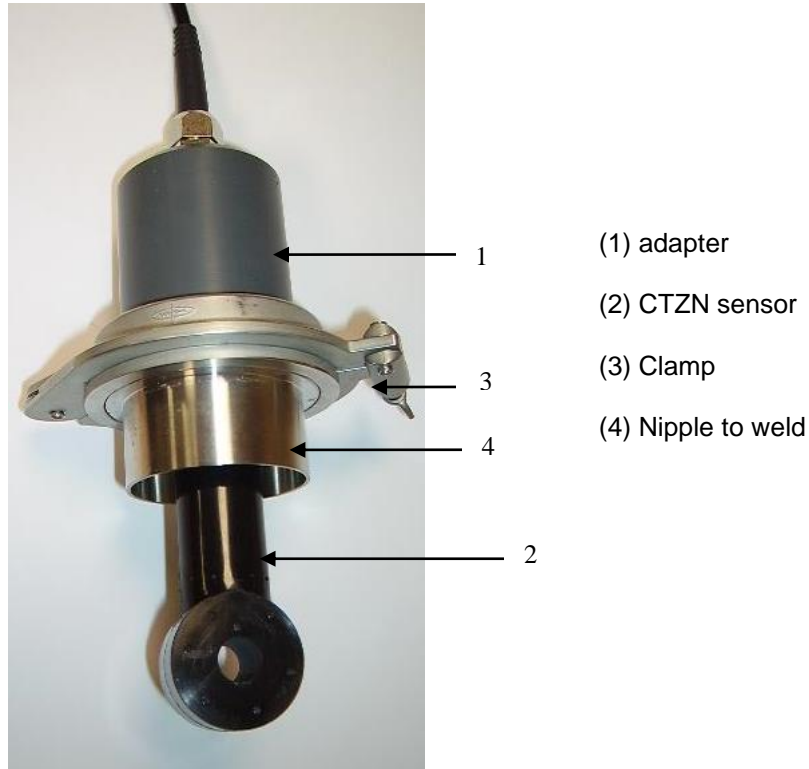

Mounting system for CTZN sensor (PF-ACC-C-00350)

- 1 After welding the clamp (3) on the stainless steel pipe, remove the clamp from the system and remove the PVC adapter (1).
- 2 Guide the sensor cable through the union nut on the adapter.
- 3 Reposition the adapter in the nipple (4).

#### 4.3 Electrical connections.

The sensor could deliver within version bare wire on 3, 7, 15 m or on other length (up to 100 m).

Power supply									
<b>Power requirements</b>	5 to 12 volts for cable 0-15 m 7 to 12 volts for cable >15 m Max. 13.2 V								
<b>Consumption</b>	<b>Automatic Standby &lt; 50 μA , Heating time 100 mS</b> <b>Average Modbus RS485/ Range 0-100 mS/cm</b>								
	<table border="1"> <thead> <tr> <th></th> <th>Vin 5V</th> <th>Vin 12 V</th> <th>Vin 24 V</th> </tr> </thead> <tbody> <tr> <td>1 measure/s</td> <td>31 mA</td> <td>15,5 mA</td> <td>11,5 mA</td> </tr> </tbody> </table>		Vin 5V	Vin 12 V	Vin 24 V	1 measure/s	31 mA	15,5 mA	11,5 mA
		Vin 5V	Vin 12 V	Vin 24 V					
1 measure/s	31 mA	15,5 mA	11,5 mA						
Max current pulse 700 mA during 2 mS, 350 mA during 150 mS									

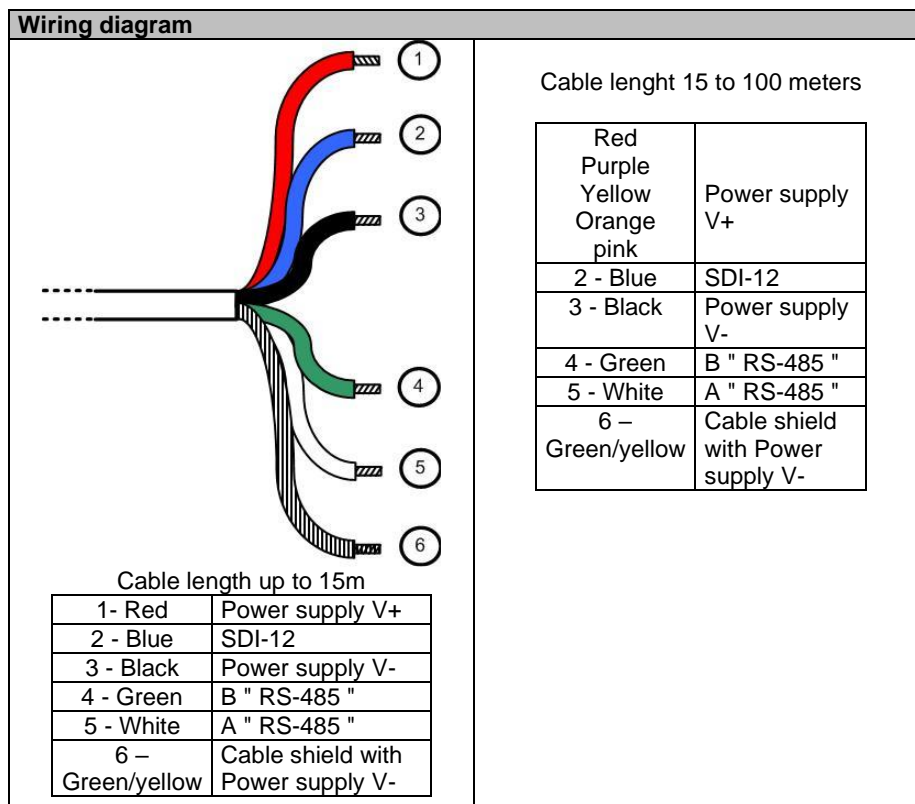

## 5. Startup and maintenance.

### 5.1 Initial startup

Once the sensor is connected to your terminal, the sensor is settled in its accessory of assembly and the parameterization has been carried out on the display unit, the sensor is ready for initial startup.

➤ **Note :**

During the introduction of the sensor in measurement environment, wait for sensor's temperature stabilization before measure processing.

➤ **Started :**

### 5.2 Calibration

The calibration of the conductivity sensor is a 2-step process:

- Step 1 (offset): Expose the sensor to the air to perform the first stage of the Calibration process. The value for this first calibration standard is set to 0 0  $\mu\text{S}/\text{cm}$ .

- Step 2 (gain): the sensor is placed in a buffer solution of known conductivity 12,88 mS/cm. Let stabilize during 5 minutes.

### 5.3 Maintenance:

The sensor not being sensitive to the fouling, there is no particular maintenance to be planned. However, assure hthat the central part of the sensor is not blocked.

AQUALABO Hotline  
115 Rue Michel MARION  
56850 CAUDAN  
FRANCE

Tel.: +33 (0) 4 11 71 97 41  
Email: [sav@aqualabo.fr](mailto:sav@aqualabo.fr)