

TP08

Small Size Non-Steady-State Probe for Thermal Conductivity Measurement



TP08 manual v2012

Edited & Copyright by:

Hukseflux Thermal Sensors
<http://www.hukseflux.com>
e-mail: info@hukseflux.com



Warnings:

Putting more than 3 volt across any part of TP08 may result in permanent damage to the sensor.

The user is responsible to take care that TP08 is not overheated during operation.

The TP08 needle is vulnerable. In case of doubt if it can penetrate the sample, the sample should be pre-drilled.

The TP08 needle is vulnerable. When not being used, it is recommended to have the protective cover over the needle.





Contents

	List of symbols	4
	Introduction	5
1	Theory	7
	1.1 When to use TP08	7
	1.2 General Non-Steady-State Probe (NSSP) Theory	7
	1.3 TP08 design	10
	1.4 Directions for performing a correct measurement	11
	1.5 Container TP08	13
2	Specifications of TP08	14
3	Short user guide	16
	3.1 Installation of TP08	16
	3.2 Putting TP08 into operation	17
	3.3 Performing a normal measurement, calculating the end result	19
4	Electrical connection of TP08	22
5	Programming for TP08	26
6	Maintenance of TP08	28
7	Delivery and spare parts	29
8	Appendices	30
	8.1 Appendix on modelling TP08 behaviour	30
	8.2 Appendix on ASTM and IEEE standards	32
	8.3 Appendix on the requirements for the Measurement and Control Unit (MCU)	33
	8.4 Appendix on thermopile temperature dependence	34
	8.5 Appendix on insertion of the needle into hard media	35
	8.6 Appendix on typical thermal properties	37
	8.7 Appendix on TP08 calibration	38
	8.8 Appendix on agar gel	39
	8.9 Appendix on cable extension and connectors for TP08	40
	8.10 Appendix on comparing 1-needle to 2-needle techniques	41
	8.11 Appendix on trouble shooting	42
	8.12 Appendix on quality assurance	44
	8.13 Appendix with measurement form / test report	45
	8.14 Appendix on literature references	46
	8.15 CE Declaration of Conformity	47





List of symbols

Thermal diffusivity	a	m^2/s
Distance from the heater	r	m
Heating cycle time	h	s
Thermal conductivity	λ	W/mK
Voltage output	U	V
Sensitivity	E	V/K
Time	t	s
Response time	τ	s
Temperature	T	K
Differential temperature	ΔT	K
Electrical resistance	R_e	Ω
Electrical resistance per meter	R_{em}	Ω/m
Thermal resistance	R_t	m^2K/W
Thickness	H	m
Diameter	D	m
Length	L	m
Area	A	m^2
Volumetric heat capacity	C_v	J/Km^3
Heat capacity	C	J/kg
Density	ρ	kg/m^3
Heat flux	Φ	W/m^2
Current	I	A
Mass	M	kg
Volume	V	m^3
Power	P	W
Power per meter	Q	W/m
Intermediate variables	x, w, z	-
Error in a variable	δ	-

Subscripts

Property of thermopile sensor	sen
Property of the current sensing resistor	current
Property of the heater	heat
Property of the medium	med
Property of the needle	needle
Property, at $t = 0$, at $t = 180$, $t = h$ seconds	0, 180,





Introduction

TP08 is a high quality probe that offers the possibility to do a practical and fast measurement of the thermal conductivity or thermal resistivity of the medium in which it is inserted. It works in compliance with the ASTM D5334-14, D5930-97 and IEEE 442-1981 standards. The TP08 is a small Version of TP02. It has the advantage that compared to measurements with TP02 smaller samples can be used. A disadvantage is that, because there is no cold junction in the medium, the medium and base must be thermally more stable or a higher heating level must be used. The standard TP08 probe has proven suitability in soils, foodstuff and various other materials. The Non-Steady-State Probe (NSSP) measurement method (also known as transient line source, thermal needle, hot needle, heat pulse- and hot wire technique) has the fundamental advantages that it is fast and absolute while the sample size is not critical. Hukseflux is specialised in NSSP design. Sensor size and temperature range can be adapted on request. Special probes have been developed for in-situ field experiments and for use at high temperatures. TP08 has been designed and tested in collaboration with the Applied Physics Group of Wageningen University.

The single needle of TP08 makes it very suitable for repeated insertion into various media. Whenever permanent installation is required, for instance in the soil, as part of a meteorological experiment the type TP01 is preferred. A separate manual is available.

Chapter 1 contains information about theory and design of the NSSP, chapter 2 summarises the instrument specifications. The remaining chapters contain information about installation, connection, programming and maintenance.

For performing a measurement, TP08 has to be combined with the user's Measurement and Control Unit (MCU). The required specifications are treated in the appendix on MCU specifications. One of the most cost-effective solutions to the problem of measurement and control is to use the datalogger Campbell Scientific, type CR1000.

The end result is preferably calculated by analysis of the measured data in a spreadsheet (like MS-EXCEL) or a mathematical program. Alternatively automatic calculation of the end result in the MCU is possible.



In the appendices, several more specialised subjects are treated.

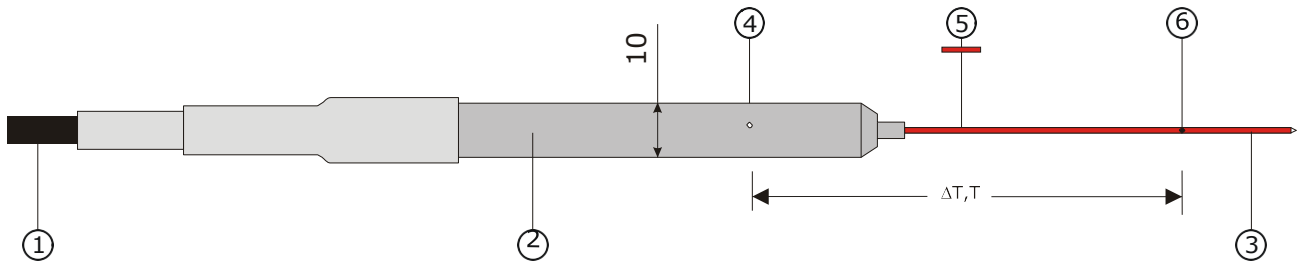

Figure 0.1 TP08 Small Size Non - Steady - State Probe consists of a needle with 1 thermocouple junction located at about 15 mm from the tip (the other junction effectively located in the base) and a heating wire. It is inserted into the medium that is investigated. In the base, a temperature sensor is mounted. Advantages of this design: the possibility to use small samples, a high sensor stability and the possibility to use normal cables and connectors.



1 Theory

1.1 When to use TP08

Hukseflux specialises in Non-Steady-State probe design. The primary model of the Hukseflux product range is the TP02. This model offers optimal measurement accuracy by a combination of its design features.

For some applications however the requirements regarding possible sample size are such that the needle length and diameter of TP02 are too large. For this category of samples, TP08 has been designed.

Having a needle length of 70 mm and a diameter of 1.2 mm, samples of around 125 ml can be analysed. (see specifications for more details).

In TP08 the reference junction of the thermocouple is located in the base. A high quality measurement with TP08 requires that not only the sample but also the base are at a stable (preferably the same) temperature.

Usually this is achieved by clamping the base into the same material (metal) that holds the sample.

Because of the relative importance of the thermal equilibrium between base and sample, an optional sample container can be ordered with TP08.

1.2 General Non-Steady-State Probe (NSSP) Theory

For determining the thermal conductivity of materials various types of measurement equipment can be used. In general one can make a distinction between steady-state techniques in which the investigated sample is supposed to reach a perfect thermal equilibrium, and non-steady-state techniques. In non-steady-state techniques the material properties are determined while the sample temperature still changes.

The main advantage of steady-state techniques is the simplicity of the analysis of stabilised constant sensor signals. The main advantages of non-steady-state techniques is the short measurement time and the fact that the sample dimensions do not necessarily enter the equation.





The only Non-Steady-State technique that has been standardised is the one using a single needle probe like TP08.

ASTM D5334-14 and D5930-97 and IEEE Std 442-1981 "Standard Test Methods" specify the use of the NSSP in various applications. In particular, use in plastics, soil and soft rock are mentioned, but the method is not restricted to these materials. More information about these standards can be found in the appendices.

In general a NSSP consists of a heating wire, representing a perfect line source and a temperature sensor capable of measuring the temperature at this source. The probe is inserted in the medium that is investigated. The NSSP principle relies on a unique property of a line source: after a short transient period the temperature rise, ΔT , only depends on heater power, Q , and medium thermal conductivity, λ :

$$\Delta T = (Q / 4 \pi \lambda) (\ln t + B) \quad 1.1$$

With ΔT in K, Q in W/m, λ in W/mK, t the time in s and B a constant.

The thermal conductivity can be calculated from two measurements at t_1 and t_2 . For TP08 both t_1 and t_2 are higher than 30 s, and typically 50 s apart. Now ΔT the temperature difference between t_1 and t_2

$$\lambda = (Q / 4 \pi \Delta T) \ln(t_2 / t_1) \quad 1.2$$

The sample size is not critical, as long as a radius around needle is covered that is roughly 50 times the needle radius, in case of TP02: 30 mm.



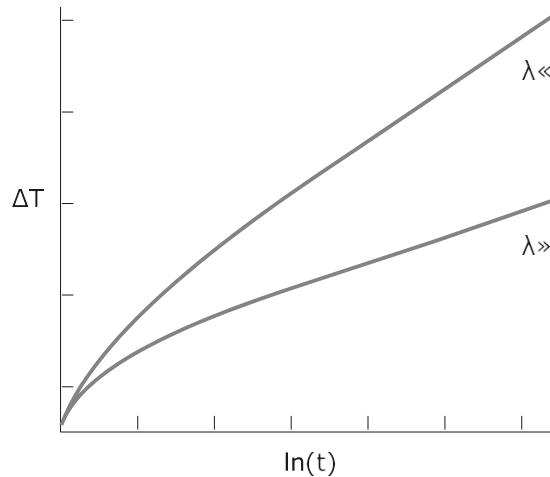

Figure 1.2.1 *The signal of TP08 as a function of the natural logarithm of time. After a transient period the graphs show linear behaviour. In this phase the slope of the graph is inversely proportional to the thermal conductivity λ .*

The formula 1.2 is a first order approximation that is only valid under certain conditions.

The most important ones are that the medium has reasonable thermal contact with the probe, and that the sample is thermally stable. More details can be found in the specifications and the directions for performing a correct measurement later in this chapter. More details on the mathematics and literature references can be found in the appendix.

Whether TP08 has passed the transient period is usually checked by visual examination of the graph.

The measurements of Q , t and ΔT are all direct measurements of power, time, and temperature and are done without need of reference materials. The measurement with TP08 is absolute.





1.3 TP08 design

TP08 has been designed:

- 1 to cover a wide range of applications with primary focus on soils and foodstuff
- 2 to be as reliable as possible
- 3 to have stable long term behaviour
- 4 to be compliant with existing standards
- 5 to produce relatively simple measurement results, allowing own data processing.
- 6 to have a traceable calibration
- 7 to allow a small sample size

and for a user who has his own high accuracy data acquisition and control system:

- 8 to be applicable / compatible with commercially available general laboratory equipment
- 1 Covering a wide range of applications: The TP08 has an all stainless steel housing. It is able to work in a variety of environments and is more robust than housings that are partially made out of plastic.
 - 2 Producing reliable results: A particular advantage over two-needle designs is that bending the needle does not significantly influence the TP08 measurement. In two-needle designs bending the needles causes the sensitivity to change.
 - 3 Stable long term behaviour: TP08 is completely sealed. It has a welded tip. This no-compromise sealing guarantees the long term stability of the sensor. Designs with glued sealing or epoxy housings are less reliable in this respect, particularly when working in moist environments.
 - 4 Complying with standards: For institutes that prefer to work according to standardised procedures: The measurement with TP08 is compliant with the ASTM standards D5334-14 and D5930-97. Other probe models do not comply with these standards.
 - 5 Data processing: a single needle design has a fairly simple signal analysis, only involving the conversion of the signal to a logarithmic scale, and establishing the slope of the curve.
 - 6 Calibration: the TP08 measurement is absolute and traceable to the measurement of the heater resistance and the thermocouple properties. For all practical purposes however, we use agar gel at 20 degrees C which is easily obtainable and has a well-established thermal conductivity.



- 7 Sample size: TP08 can be used with very small samples. In case sample size is not critical, in general it is recommended to use TP02.
- 8 Application: TP08 can be employed by any laboratory having a high accuracy voltmeter, resistance meter (for Pt1000) and equipment to do the proper switching / timing of the experiment.

1.4 Directions for performing a correct measurement

From experiments and the literature, the following conclusions were drawn:

In general the TP08 has proven to be suitable for laboratory use. It has shown to be sufficiently robust to survive common handling. In our samples the probe could be inserted without help. Some sample types, like hard soil might require pre-drilling.

Field use is possible but is unlikely to reach the same level of accuracy.

- 1 Consult the product manual to see if a NSSP can be applied in the intended experiment. Most common foodstuff, soils, powders, slurry's and gels are suitable for analysis with a NSSP, so-called "suitable media".
- 2 In case of doubt, consult Hukseflux engineers.
- 3 The NSSP measurement technique can be used with TP08 to measure in the thermal conductivity range of 0.1 to 6 W / mK. The expected accuracy for carefully made measurements of suitable media at 20 degrees is +/- (3% + 0.02) W/mK.
- 4 At temperatures different from 20 degrees, the temperature dependence of the sensor must be taken into account. Nevertheless after correction there is an additional +/- 0.02% / K uncertainty.
- 5 Measurement and control equipment must be selected with care: in particular the thermocouple output measurement and the timing are critical.
- 6 The measurement must be performed with care; measurement results must be critically reviewed before acceptance. The measurement technique introduces a heat flow into the material. It is assumed that this heat is transported by conduction and that there are no temperature changes caused by other sources. The probe is supposed to be static during the experiment. If these requirements are not met the measurement can lead to false results. Examples of possible error sources are: local moisture transport /



evaporation by excessive heating, movement of the probe, change of contact resistance by phase changes, local melting by excessive heating and thermal convection when used in fluids.

- 7 The part of the graph that is analysed must be selected by the user. When analysing a known material or a material that closely resembles a known material, assuming that the contact resistance is not variable, the previously used interval can be used again. When there is no experience with the particular material, or the contact resistance varies, the detailed behaviour must be studied, and a suitable interval must be selected. The transient period varies from one material to the other and also from one probe to the other. For one and the same probe, the transient period is inversely proportional to the volumetric heat capacity of the material. In case of a larger contact resistance, the transient period will be longer. For probes of similar geometry and composition the transient period is proportional to the square of the diameter of the needle.
- 8 When working with small sample sizes, smaller than about 50 times the needle radius (for TP08 around 30 mm) around the sensor, the effects of boundary conditions must be analysed. Please consult Hukseflux.
- 9 To avoid problems like the ones mentioned under 6, the heating power must be kept as low as possible, the heating time as short as possible. In exceptional cases a fluid, grease or gel can be used to reduce the contact resistance.
- 10 The sample must be as thermally stable as possible. (more so than with TP02) Ideally not exceeding more than 0.5% of the temperature rise generated by the heater during the interval that is analysed. If the sample is not stable, the resulting signal will be added or subtracted from the real heater signal, leading to measurement errors. If the existing temperature change is linear in time, this can be compensated for by subtraction from the sensor signal.
- 11 The procedures as recommended in the ASTM standards offer a good guideline, but should not be followed under all conditions. In particular in the ASTM standards no attention is paid to the reduction of heating power and temperature rise during the experiment. Also the compensation for existing temperature gradients in the material and temperature dependence of the sensor are not considered. These omissions can lead to mistakes.





1.5 Container TP08

The purpose of the container TP08 is to create a situation with optimal conditions for the measurement with TP08. It can be ordered as an option with TP08. Essentially this requires that both sample and TP08 base are at a stable, preferably the same, temperature.

The thermal equilibrium is promoted by

- 1 adding mass
- 2 making a large contact surface between base and lid
- 3 making a large contact area between base and container

The container is constructed without any additional holes, threads etc. The purpose of this is that it is easily cleaned. The Container material is Stainless Steel 316.

The weight of the Container is 5 kg.

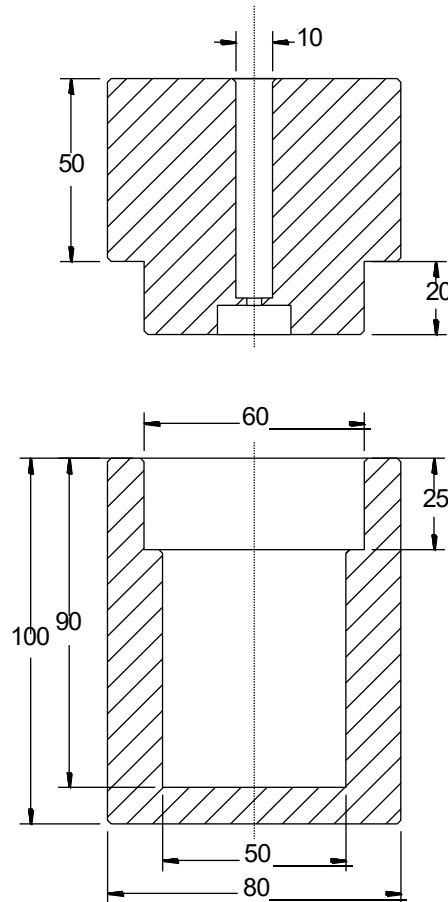

Figur 1.5.1 *Container TP08. The Container consists of a Sample Holder and a Lid. For proper operation the container must be filled up to the lowest 40 mm. Taking 80 ml. Sample size.*





2 Specifications of TP08

TP08 Small Size Non-Steady-State Probe is used for determining the thermal conductivity of the medium in which it is inserted. It can only be used in combination with a suitable measurement and control system, typically using a spreadsheet for data analysis.

GENERAL SPECIFICATIONS	
Measurement method	Absolute measurement, according to the standards ASTM D5334-14, ASTM D5930-97 and IEEE Std 442-1981.
Specified measurements	Thermal conductivity of media as specified under suitable media. Directions from the manual should be followed.
Suitable media	Granular materials (grain size smaller than 0.5 mm), powders, soils, gels, pastes, slurries, soft rock, and foodstuff and similar substances in the thermal conductivity (λ) range of 0.1 to 6 W/m.K. Some fluids are suitable.
Sample requirements	Preferably the medium is all around the TP08 needle. It must cover at least the lowest 35 mm of the needle. It preferably has a radius of > 50 mm, at least 30 mm. The sample may be pre-drilled. Contact fluid may be used. The sample must be thermally stable ($dT/dt < 0.5\%$ of the heater induced change typically, 2.5% max) and reasonably homogeneous.
Duration of the measurement cycle h	h must be as low as medium and readout allow. 100 seconds (typical). Empirically verified for each medium type.
Heating Power / m Q	Q must be as low as the medium and readout allow. Typically Q is adjustable so that the temperature rise is no more than 1 degree. Typically lower than 5 W/m.
Temperature range	-55 to +180 °C (base and cable) to +250 °C (needle)
Protection class	IP68 (needle and base) IP67 (entire probe)
ISO requirements	TP08 is suitable for use by ISO certified laboratories
CE requirements	TP08 complies with CE directives

Table 2.1 List of TP08 specifications (continued on next page)



MEASUREMENT SPECIFICATIONS	
Data analysis	Preferably in a spreadsheet (MS-EXCEL) or a dedicated mathematical program, alternatively in the MCU.
Expected accuracy	+/- (3% +0.02 W/mK) for homogeneous media with good contact to the needle.
Repeatability	+/- 1%
Temp. Dependence	< +/- 0.02%/ °C after correction of tc temp. Dependence
SENSOR SPECIFICATIONS	
Thermocouple joint	1 NiCr-NiAl type K, according to ANSI MC96.1-1882
Temperature sensor	Pt 1000, Class B, IEC 751:1983
Required readout	1 differential voltage, 1 current, 1 Pt1000 channel, storage of data points versus time.
Voltage input	3 VDC (maximum), switched, typically adjustable to the medium properties, 1 VA max.
Thermocouple Re	20 ohm (nominal)
Heater Re, length L	86.3 Ohm/m (nominal), specified for each individual sensor within +/- 0.25%, 70 mm +/- 2 mm, total 7 Ohm (nominal)
Probe dimensions	Needle: 70 by 1.2 mm, Base: 50 by 10 (+0, -0.05) mm
Cable length, type	2.5 meters, Teflon, diameter 5 mm, 6.5 mm max.
Weight	approx. 0.5 kg (including 2.5 m cable) approx. 1 kg including packaging and manual
CALIBRATION	
Calibration traceability	Thermocouple according to ANSI MC96.1-1982
Recalibration interval	Every 2 years using agar gel reference medium

Table 2.1 *List of TP08 specifications (continued from previous page).*



3 Short user guide

Preferably one should read the introduction and the section on theory.

If TP08 is supplied without a MCU, additional equipment is required:

A voltage source delivering power to the heater, and a MCU capable of switching, readout of voltages, a current, Pt1000 and timing with sufficient accuracy. If possible but not necessarily this system also should have the capability to perform calculations based on the measurement.

Specifications for this equipment can be found in the appendix. If this is available, it is recommended to use a Campbell Scientific CR1000 Measurement and Control Module.

The connection of TP08 to the MCU differs from case to case. Usually this is done using clamp connectors or high quality connectors. The wiring scheme can be found in the chapter on electrical connection.

The following chapters contain information on installation, how to put the system into operation and how a normal measurement should be performed and how the end result can be calculated.

3.1 Installation of TP08

TP08 is generally installed in a laboratory environment. The surrounding should be thermally quiet. For an optimal measurement, doors should be closed to avoid unnecessary convection. TP08 preferably works in equilibrium with ambient air temperature.

Working at different temperatures is possible by putting TP08 in a climate chamber and allowing the medium and probe come to an equilibrium. In general, during a measurement in a climate chamber it is recommended to turn active climate control and ventilation off during the measurement.

TP08 has a very broad working range, and the complete assembly can be used up to 180 degrees C.





3.2 Putting TP08 into operation

It is recommended to start with a simple test the sensor functionality by checking the impedance of the sensor and heater, and by checking if the sensor reacts to changing temperatures. After this it is suggested to perform a measurement using agar gel. With these two actions, operation is trained, and proper operation is confirmed.





<p>Check the heater impedance. Use a multimeter at the 200 ohms range. Measure between two wires that are connected at opposite ends of the heater.</p>	<p>This should be between 5 and 20 ohms. Infinite indicates a broken circuit, zero indicates a short circuit.</p>
<p>Check the impedance of the sensor. Use a multimeter at the 100 ohms range. Measure at the sensor output. Warning: during this part of the test, please put the sensor in a thermally quiet surrounding, holding the sensor in still air.</p>	<p>A typical sensor impedance should be between 20 and 60 ohms. (at 2.5 m cable. If more cable is used, add 0.1 Ohm/m back and forth, so 0.2 Ohm/m) Infinite indicates a broken circuit, zero indicates a short circuit.</p>
<p>Check the Pt1000. Use a multimeter in the 2000 Ohms range. Check opposite wires.</p>	<p>The result at room temperature should be between 900 and 1200 Ohms when the probe is close to room temperature. Infinite indicates a broken circuit, zero indicates a short circuit.</p>
<p>Check the Pt1000. Use a multimeter in the 10 Ohms range. Check between the two wires at one end of the sensor.</p>	<p>The result should be in the 0.5 ohms range. For each meter of wire, the impedance is around 0.1 Ohm. The total for 2.5 m is 0.5 Ohms.</p>
<p>Check if the sensor reacts to differential temperatures. Use a multimeter at the millivolt range. Measure at the sensor output. Generate a signal by touching the thermopile joint at half third of the needle, with your hand. If a 1.5 Volt battery or power source is available, it is also possible to connect the power source to the heater and see if a signal is generated.</p>	<p>The thermocouple should react by generating a millivolt output signal.</p>

Table 3.2.1 *Checking the functionality of the TP08. The procedure offers a simple test to get a better feeling how TP08 works, and a check if the system is OK.*





The next step is to perform a measurement using agar gel.

Put the probe in agar gel.	Directions how to prepare agar gel can be found in the appendix.
Perform a measurement	Directions from the chapter on performing a normal measurement can be followed.
Calculate the end result	Directions from the chapter on calculation of the measurement result can be followed.
Compare the measurement results with the data of the sheet	The difference between the data and the measured result should not exceed +/- 3%

Table 3.2.2 *Checking the instrument performance by making a first measurement using agar gel.*

3.3 Performing a normal measurement, calculating the end result

Having prepared all the necessary equipment, and having tested the system, performing a normal measurement is easy.

Perform a measurement keeping in mind the recommendations of chapter 1. In general the total heating cycle time is called h . It is recommended to wait for a period of h before the measurement to verify if the thermal environment is stable. Any significant thermal gradient that occurs over this period, can be subtracted from the thermal gradient during the measurement. The total measurement takes 2h seconds.
Retrieve the measured data, preferably with a 10 second resolution or better to a spreadsheet.
Verify that the measurement reached a linear dependence on $\ln(t)$.
Select a suitable portion of the graph, and calculate the result, based on formula 1.2.
Perform quality assurance. Suggestions can be found in the appendix.

Table 3.3.1 *Performing a normal measurement.*



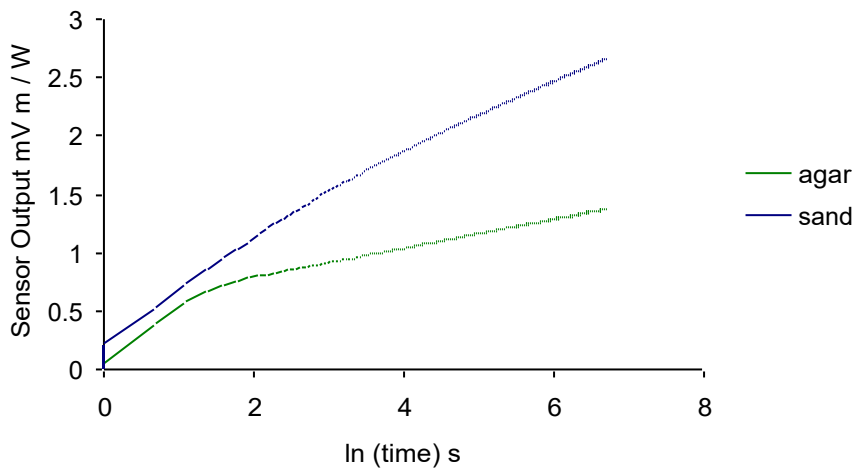

Figure 3.3.1 Typical measurement results in agar gel and dry sand. The thermal conductivity's are 0.6 and 0.3 respectively. The linear portions of the graph have to be selected by the user. The graph illustrates that the portion that is suitable for analysis changes from one medium to the other.

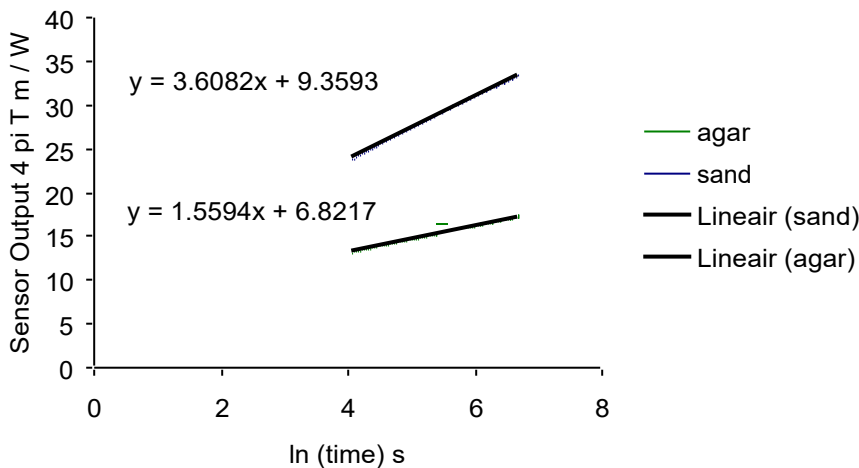

Figure 3.3.2 Example of data analysis in MS-Excel. See also formula 1.1. A linear portion of the graph of the figure 3.3.1 has been selected. The temperature T has been multiplied by 4π and divided by the heating power per meter. The Excel program can automatically calculate the best linear fit. The end result for the thermal conductivity's is $1/3.608$ and $1/1.559$, which is 0.27 and 0.64 respectively.

The following formula's have been used are 1.1 and 1.2 and (see the list of symbols for explanation of the units):



For the calculation of Q, the power per meter:

$$Q = (U_{\text{current}} / R_{\text{e current}})^2 R_{\text{em heat}} \quad 3.3.1$$

This formula is valid if a current sensing resistor is used. Please mind that Rem is in Ohm per meter.

$$\Delta T = U_{\text{sen}} / (E_{\text{sen}} (1 + (dE_{\text{sen}} / dT) T)) \quad 3.3.2$$

$(dE_{\text{sen}} / dT) T$ is the temperature correction of the thermocouple temperature dependence.



4 Electrical connection of TP08

In order to operate, TP08 should be connected to a measurement and control system as described in the appendix.

The wiring schedule is shown in figures 4.1 and 4.2.

NOTE: Although the internal wiring is slightly different, the same wire configuration as for TP02 is used.

For the purpose of making a correct measurement of the heater power, Q_{heat} , there is a

2-wire connection to the heater. Two wires carry the current. The current should be measured. Typically this is done using a shunt resistance. Typically 3 voltage levels are supplied, for instance: 2VDC, 1VDC and 0.7 VDC. These can be switched by relays.

The Pt1000 also has a 3-wire connection. The thermocouple signal, representing the differential temperature between base and medium, should be added to the Pt1000 signal to get the medium temperature. In this configuration the Pt1000 serves as a cold junction compensation for the thermocouple.

The thermocouple sensor only needs a voltage readout.

Warning:

putting more than 3 Volt across the heater may result in permanent damage to the sensor.



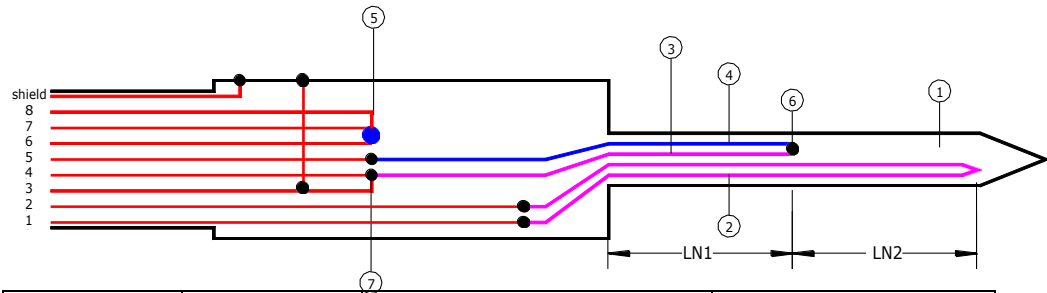

Number	Group	Name	Colour
1	1	heater +	black
2	1	heater -	black
3	2	sensor -	white
4	2	Not functional with TP08	Yellow with red sleeve
5	2	sensor +	Yellow
6	3	Pt1000 current -	White
7	3	Pt1000 current +	Red
8	3	Pt1000 sensing	Red
Shield			Grey
Base		connected to number 3 and shield	

Figure 4.1 *Wiring schedule of TP08. The wiring is kept exactly the same as TP02, to allow the use of the same programs.*

1	Measurement of heater power per meter by combining the heater current measurement (here using a voltage measurement across a 10 Ohm resistor as an example) with the heater resistance per meter (given with each probe).
2	Measurement of the sensor signal, done by measuring V1, and later determining the temperature difference using the thermocouple sensitivity and the approximate needle/medium temperature.
3	Estimate of the needle/medium temperature. For TP08 this is assumed to equal the base-Pt1000 temperature

Table 4.1 *The main measurements summarised*



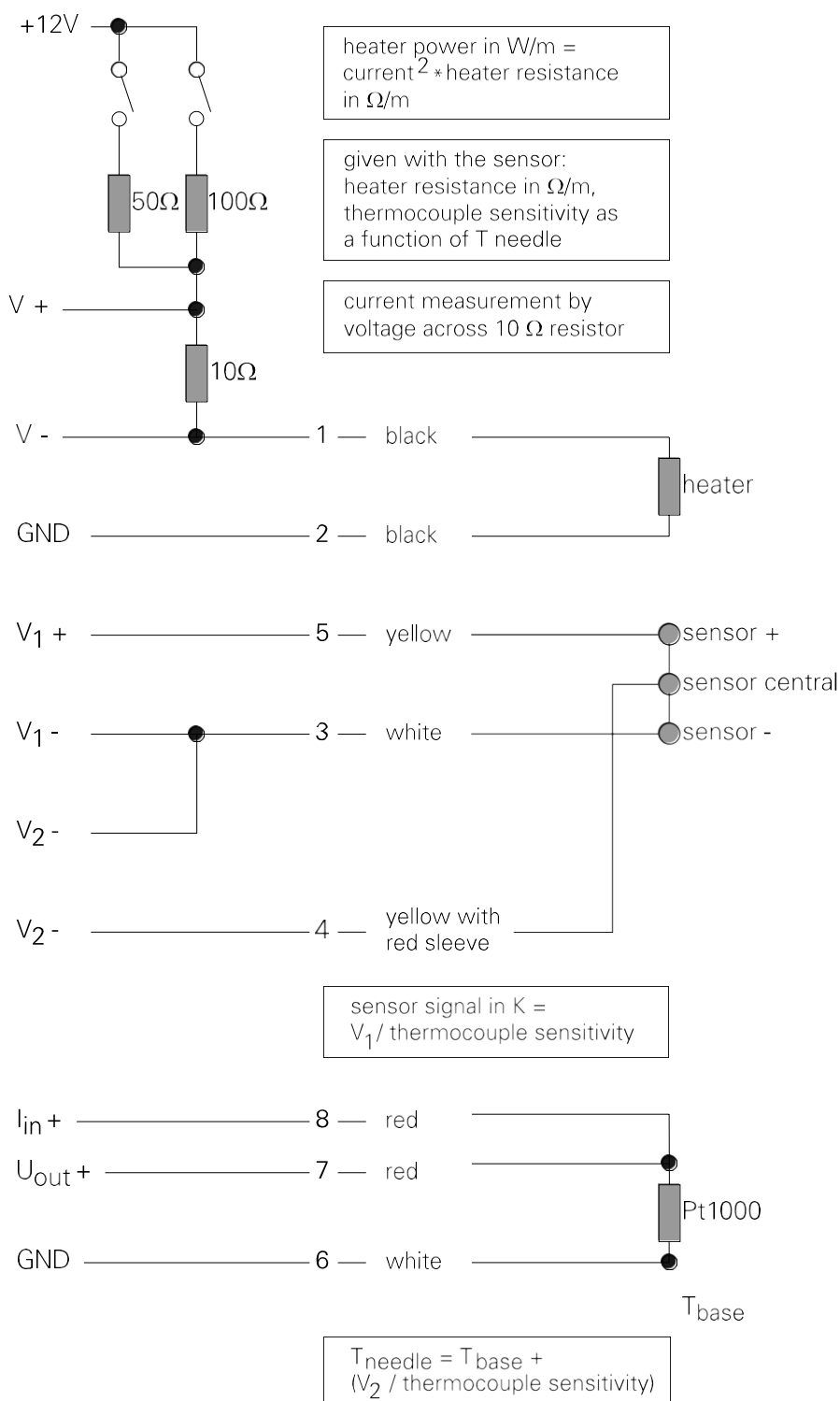

Figure 4.2 Typical wiring diagram of TP08 to a measurement and control system. Two main functions are the measurement of heater power per meter, the measurement of the differential temperature between hot and reference junction. For correction of the temperature dependence the medium/needle temperature must be roughly estimated. NOTE; For TP08 V2 always equals zero; the central connection is not functioning.



The upper left shows a possible solution for switching different power levels and for performing current measurements. This solution is not the only correct possibility.





5 Programming for TP08

The TP08 measurement protocol and the necessary calculations are outlined in earlier chapters. Here follows a summary of the general program. NOTE: the same program as for TP02 may be used.

Setting up the system	Allow entering the default values	The parameters of E_{sen} , $R_{e\ heat}$, dE_{sen}/dT , and h are entered as default values. It should be noted that these can change and should be user definable.
Before every experiment	Allow entering parameters for every measurement	Like sample number, experiment number etc
	Allow choosing the heating cycle time	The cycle time can vary between 50 and 1000 seconds.
	Allow selection of the heater power	Typically there is a choice of 3 levels. With one voltage supply, these can be derived using 2 resistors and 2 relays.
$t = 0$	Wait for a period h to allow the probe to adjust to the medium temperature. Measure $U_{sen\ 0}$. Store these data at a certain interval. Determine T . Use T to correct the temperature dependence of the thermocouple sensitivity.	
After a period h	Measure $U_{sen\ h}$ and $I_{heat\ h}$	If the temperature gradients through the medium are zero and the electronics are perfect, this signal will be equal to zero. In practice, it will have a value different from zero.
	Store $U_{sen\ h}$ and $I_{heat\ h}$ and T_h ($t = h$ seconds)	





t = h	Switch heater on. This must be accurately timed.	At t = h, the zero reading is taken. After this, the heater is switched on.
At least every 10 seconds	Measure the current $I_{\text{heat } t}$ and $U_{\text{sen } t}$	Optional quality assurance: see if the signal rises continuously.
	Calculate the heater power using $R_{\text{e heat}}$	
t = 2h	Switch off the heater	
	If the MCU allows this, the end result can be calculated, and quality checks can be made, and even the measurement result can be calculated.	See the appendix on this subject for quality assurance. For analysis of the measurement data a common approach is to calculate the signal gradient over a series of intervals. This can be from 1.5h to 2h, from 1.6h to 2h, from 1.7h to 2h. The standard deviation of these gradients offers an automatic way to see if the transient period is over or not. The gradient before the measurement and the temperature are used for correction.

Table 5.1 *Typical ingredients of a program for measurement and control of TP08.*





6 Maintenance of TP08

TP08 does not need a lot of maintenance. After use the equipment can be cleaned using water. Usually errors in functionality will appear as unreasonably large or small measured values. As a general rule, this means that a critical review of the measured data is the best form of maintenance. At regular intervals the quality of the cables can be checked. On a yearly interval the calibration can be checked.

Every 1 year	Perform on site calibration of TP08 using agar gel
Every 2 years	Perform calibration of the MCU.

Table 6.1 *recommended schedule for calibration of TP08 and MCU.*





7 Delivery and spare parts

TP08 delivery includes the following items:

TP08
Protection tube

Manual TP08
Calibration form for TP08

Container TP08

The TP08 delivery does NOT include the MCU or the Container TP08.

TP08 can be delivered with extended cable. However, the delivery time of units with cable extension is significantly longer than that of standard sensors.



8 Appendices

8.1 Appendix on modelling TP08 behaviour

Modelling a finite line source is the subject of many scientific publications. Various efforts have been made to estimate errors and to improve the model such that a more accurate measurement can be attained.

The analytical solution to the problem is known. This involves the fact that the probe has a certain geometry, no significant conduction along the probe itself and has different thermal properties than the medium. Also it assumes that there is a certain constant contact resistance between the probe and medium. The equation is given in Kosky and McVey.

On the other hand in most applications the ideal model, without considering probe thermal properties and contact resistance is used:

$$\Delta T = (Q / 4 \pi \lambda) (\ln t + B) \quad 1.1$$

It turns out that also if contact resistance and different thermal parameters are involved, the long time solution of the analytical model and the ideal model lead to the same result for λ . The only difference is that B is larger in the analytical model because of the contact resistance. In other words, the effects of the probe thermal properties and contact resistance are no longer visible some time after the heating has started. Because B cancels from the equation for determination of λ , 1.2 is still applicable.

$$\lambda = (Q / 4 \pi \Delta T) \ln(t_2 / t_1) \quad 1.2$$

The normal transient period under ideal conditions is:

$$t_{\text{transient}} = 10 D^2 / a \quad 8.1.1$$

Under ideal conditions this means that the transient time is proportional to the medium thermal diffusivity a , and the probe cross section (D is the diameter). The only consequence of the addition of contact resistance and probe thermal properties, is that the transient period will take longer.

The remaining measurement error has been analysed by various authors. Conclusions are that the main parameters determining the transient period are R_{cont} , the contact resistance, and C_v





$\frac{\text{needle}}{C_v \text{ med}}$, the ratio of the volumetric heat capacities. The higher the contact resistance and the lower the medium volumetric heat capacity, the longer the transient time.

Theoretically, it would be best to take the measurement time of more than 10 minutes. This is not possible because of three reasons:

- 1 the temperature rise becomes too small relative to the temperature changes induced by outside sources.
- 2 there is a risk that the boundary conditions of the sample start playing a role.
- 3 there is a risk that the total energy that is released into the medium becomes so large that the condition of the medium is affected.

Various attempts have been made to simplify the measurement procedure. There has been limited success. The general recipe now is: take a look at the contact resistance. If a large contact resistance is expected, and the medium allows the use of contact fluid or grease (like toothpaste, agar gel, glycerol or Vaseline) can be considered. This is often applied when analysing rock samples.

After this, consider the medium volumetric heat capacity (see the table on thermal properties). This table clearly shows that the materials that have a very low volumetric heat capacity are those with a large porosity, containing air. In practise these materials also have a very low thermal conductivity, as well as a fairly normal thermal diffusivity. It is the heat capacity that forces to use very long measurement times. However, the thermal diffusivity is such that we would also need very large samples. This combination, and not the low thermal conductivity as such, makes these materials unsuitable for analysis by NSSP methods.

In practise, the limitation of the measurement range from 0.1 to 6 W/mK prevents us from making serious measurement errors.

This means that for all practical purposes for the measurement of thermal conductivity's the model of formula 1.2 can be used.

Regarding the accuracy of the measurement; the estimate of +/- (3%+0.02)W/mK is derived from various literature sources. For more details, see the list of references.





8.2 Appendix on ASTM and IEEE standards

With TP08 it is possible to perform measurements in accordance with the ASTM and IEEE standards. These standards are:

ASTM D5334 - 14 Standard Test Method for Determination of Thermal Conductivity of Soil and Soft Rock by Thermal Needle Probe Procedure and ASTM D5930 - 97 Standard Test Method for Thermal Conductivity of Plastics by Means of a Transient Line Source Technique

Both standards can be obtained from ASTM. For information see <http://www.astm.org>.

IEEE Std 442-1981, IEEE Guide for soil Thermal Resistivity Measurements.

Resistivity is the inverse of the conductivity. This parameter is not used in the text of this manual.

The IEEE standard can be obtained from IEEE. For information see <http://www.ieee.org>.

For full compliance with ASTM, it is necessary to follow the procedures described in the respective standards. Hukseflux suggests to allow slightly modified specifications. The described deviations are positively affecting the quality and practicality of the measurement, and altogether compliance with the standards can be stated when following the recommendations in this manual in addition to those in the standards.

Based on practical grounds, the ASTM D 5930-97 calibration against fused silica is replaced by calibration against agar gel. On physical grounds most importantly, the application is not limited to soil, soft rock and plastics. Also the measurement time of 1000 s is replaced by a measurement time of 200 seconds and the temperature range is extended from " 20 to 100" to " -55 to +180" . In comparison to ASTM 5334-14, again the temperature range is different. Also the thermal conductivity range is not applicable.





Again the calibration medium is changed on practical grounds. The recommended sample radius of ASTM 5334-14 is judged to be too small and could lead to serious errors.

Conclusion: For compliance with ASTM standards, the procedure of the respective standard must be followed with a few, well motivated exceptions.

The IEEE standard is specifically written for application in the power industry, for estimating thermal budgets of electrical cables. There is a clear distinction between field measurements and laboratory measurements. In general TP02 will be used in laboratory situations. Hukseflux can offer alternative needle designs for field use.

8.3 Appendix on the requirements for the Measurement and Control Unit (MCU)

The MCU performs the measurement and control of the TP02. The evaluation is done in a spreadsheet like MS-EXCEL, or in a mathematical program like Matlab.

The total number of measurements that needs to be made is:

U_{sen} : voltage

I_{heat} : current

U_{temp} : voltage

Pt-1000

timing

Further it is necessary to store the measured data.

The requirements for the MCU are summarised in the following table.

Capability to measure voltage (U_{sen})	approx. -2.5 to +2.5 mV, with 0.001 mV or better accuracy. A zero offset does not influence the measurement as long as it is constant.
Capability of measuring currents	Approx. 0.3 A max, 0.1% accuracy, typically done with a 10 ohm shunt resistor.
Capability of switching	Max 3 volt at 0.3 A approx. For the heater, preferably with 2 relays offering 3 heating levels at 0.5 and 0.25 of the





	maximum.
Capability of measuring Pt1000	+/- 3 degrees accuracy
Capability of timing the measurement	The measurement timing and timing of the switching should be accurate to within 0.01 seconds.
Requirements for power supply of the heater	Capability to supply 3 Volt DC stable within 0.2%, at 0.3 A max. This can be achieved with any normal 12 V adapter, provided that the mains power supply is stable.
Capability for the MCU or the software.	To store the entire data set, including the time of measurement. Possibly performing calculations.

Table 8.3.1 *Requirements for measurement and control.*

8.4 Appendix on thermopile temperature dependence

The TP08 sensor consists of thermocouples type K, according to ANSI MC96.1-1882.

The sensitivity of this thermocouple type is 40.35 µV/K at 20 °C. However, the thermocouple sensitivity is temperature dependent and varies with about 0.2%/K. This produces a significant error; working at 10 °C instead of the 20 °C reference temperature produces an error of 2%.

The temperature dependence can be corrected by measuring the heat sink temperature using the Pt1000:

$$E_{sen} = 10^{-6} (39.40 + 0.050 T - 0.0003T^2) \tag{8.4.1}$$

This approximation will be accurate within 1% between -40 and +100 °C.





8.5 Appendix on insertion of the needle into hard media

During the measurement, the TP08 needle should be completely in contact with the medium. It should be in a perfectly static position, with no possibility of movement. Usually this is achieved by fixation of the cable or by using the Container TP08. In case of soft media the needle often can be inserted without any particular trouble. In case of hard media like hard soil, a hole may be pre-drilled.

There are two possibilities for pre-drilling:

<p>In case of modestly hard media: 1.2 mm diameter pins can be used to prepare the path for the TP02 needle. Normally the heating cycle time can remain unchanged. The measurement accuracy will not be affected.</p>	<p>To improve contact between needle and medium, the medium around the TP08 needle is typically compressed manually. The degree of compression should be no more than that of the undisturbed medium.</p>
<p>In case of hard media: Pre-drilling using a small diameter drill or metal pin is possible. The smaller the drill or pin diameter, the better. A diameter of up to 6 mm is recommended, up to 1 cm is allowable in extreme cases. The heating cycle time must be increased. The measurement accuracy can be maintained using careful visual checks of the data.</p>	<p>In this case a hole is created that has a significantly larger diameter than that of the TP08 needle. In this case the use of contact material is necessary.</p>

Table 8.5.1 *Two possibilities for pre-drilling*

Using a large diameter metal pin or a drill essentially increases the TP08 needle diameter. As the normal TP08 diameter is very small, this is not a fundamental problem. However, in order to make sure that the contents of the hole do not play a role in the measurement, three measures need to be taken

<p>After inserting the TP08 needle the hole must be filled with contact material. This can either be the original medium, now loose, or a gel (solidified agar) or paste (any white toothpaste or silicone glue). In any case the presence of fluid</p>	<p>Loose medium can be compressed as much as possible around the TP08 probe by hand. Agar gel can only be used in saturated soils, because it typically loses some water. For dry or semi-moist media, toothpaste is preferred over</p>
---	---





materials that might have thermal convection, in the hole must be avoided.	silicone glue because of its relatively high thermal conductivity.
The heating cycle duration is increased from the usual 50 with the square of the diameter to a maximum of approximately 1000 s.	This is to make sure that the heat generated by the TP08 extends well beyond the diameter of the hole

Table 8.5.2 *Measures taken after pre-drilling with a small diameter drill or with a metal pin with a larger diameter than the probe.*



8.6 Appendix on typical thermal properties

	Thermal conductivity @20°C	Density @20°C	Volumetric heat capacity @20°C	Thermal diffusivity @20°C
	W/mK	Kg/m ³	10 ⁶ J/m ³	10 ⁻⁸ m ² /s
Air	0.025	1.29	0.001	1938
Glycerol	0.29	1260	3.073	9
Water	0.6	1000	4.180	14
Ice	2.1	917	2.017	104
Olive oil	0.17	920	1.650	10
Gasoline	0.15	720	2.100	7
Methanol	0.21	790	2.500	8
Silicone oil	0.1	760	1.370	7
Alcohol	0.17	800	2.430	7
Aluminium	237	2700	2.376	9975
Copper	390	8960	3.494	11161
Stainless Steel	16	7900	3.950	405
Aluminium Oxide	30	3900	3.413	879
Quartz	3	2600	2.130	141
Concrete	1.28	2200	1.940	66
Marble	3	2700	2.376	126
Glass	0.93	2600	2.184	43
Pyrex 7740	1.005	2230	1.681	60
PVC	0.16	1300	1.950	8
PE	0.25	2200	2.046	12
PTFE	0.25	2200	2.200	11
Nylon 6	0.25	1140	1.938	13
Corian (ceramic filled)	1.06	1800	2.307	46
Sand (dry)	0.35	1600	1.270	28
Sand (saturated)	2.7	2100	2.640	102
Glass pearls (dry)	0.18	1800	1.140	16
Glass pearls (saturated)	0.76	2100	2.710	28
Wood	0.4	780	0.187	214
Cotton	0.03		0.001	
Leather	0.14		0.001	59
Cork	0.07	200	0.047	150



Foam glass	0.045	120	0.092	49
Mineral insulation materials	0.04	100	0.090	44
Plastic insulation materials	0.03	50	0.100	30

Table 8.6.1 *A list of typical values of thermal properties of various materials. This list is only indicative and can serve for estimating the medium thermal conductivity.*

Range of all reported values for soil	0.15 to 4
Saturated soil	0.6 to 4
Sand perfectly dry	0.15 to 0.25
Sand moist	0.25 to 2
Sand saturated	2 to 4
Clay dry to moist	0.15 to 1.8
Clay saturated	0.6 to 2.5
Soil with organic matter	0.15 to 2
Solid Rocks	2 to 7
Tuff (porous volcanic rock)	0.5 to 2.5

Table 8.6.2 *Reported values, as known to the author, of thermal conductivity in different soil types in W/mK.*

8.7 Appendix on TP08 calibration

TP08 provides an absolute measurement. What is meant by this is that the measurements done in a TP08 in order to derive the thermal conductivity (Q , T , and ΔT) are all direct measurements of temperature and power. This is contrary to relative methods, that require reference materials. The instrument traceability is to length, voltage and temperature. The traceability to temperature is via ANSI MC96.1-1882.

The TP08 characteristics essentially are determined by the characteristics of the thermocouple, the heater and the Pt1000. These are considered to be known for every TP08. Apart from the heater resistance per meter, they are the same for every TP08. During production proper system performance is checked by measuring the thermal properties of agar gel at 20 degrees C.





Calibration of TP08 can be done in any laboratory that has the necessary electronic equipment. The requirements for power supply and readout can be found in the chapter on MCU requirements.

The procedure for calibration is as follows:

There should be perfect contact between the needle and the gel. One can perform a calibration by doing a normal measurement, in agar gel. Knowing the thermal properties of the gel, the deviation from perfect behaviour can be calculated.

When deviating within ($6\%+0.04 \text{ W/mK}$), twice the accuracy, (plus if performed at temperatures different from 20 degrees 0.02% times the number of degrees from 20 degrees C), it is suggested not to change the calibration information. If the deviation of the measurement is outside the range mentioned above, it is recommended to adapt the calibration of the heater resistance accordingly, and leave the thermocouple sensitivity unchanged.

If the calculated thermal conductivity is lower than expected by a certain percentage, the apparent output is too high relative to the apparent heating power. This can be corrected by assuming that a higher power has been applied, which is achieved by increasing the heater resistance in Ohm/m by the same percentage.

If possible, the calibration can be performed at different temperatures.

8.8 Appendix on agar gel

The procedure for calibration relies on the use of agar gel. This is a water based gel, of which the ingredients can be bought in every pharmacy.

The agar gel is often use for growing bacteria.

The agar itself does not significantly influence the thermal properties of water, but eliminates the effects of convection.

The properties of agar gel at 0.4 mass % closely resemble those of water:

Thermal conductivity: 0.60 W/m.K , at 20 degrees C.

Thermal conductivity: 0.57 W/m.K , at 0 degrees C.

Thermal diffusivity: $0.14 \cdot 10^{-6} \text{ m}^2/\text{s}$

Temperature dependence of the thermal conductivity: $0.0015 \text{ W/mK/}^\circ\text{C}$.



Temperature range that agar gel can be used: 5 to 80 degrees C.

Generally preparation of agar gel can be done by cooking about 4 grams of agar in 1 litre of water, for about 20 minutes, stirring regularly. The solution can be put in a pot, and be allowed to cool down and solidify. This typically takes some hours. Once at room temperature, the TP08 can be inserted into the agar gel.

8.9 Appendix on cable extension and connectors for TP08

Warning: It is a general recommendation to keep the distance between MCU and sensor as short as possible and to avoid using connectors or soldered joints whenever possible.

Warning: Teflon cable cannot properly be glued, and therefore connections using sleeves cannot be considered waterproof. Also the temperature specification of

The standard sensor has a cable length of 2.5 meters. Cables generally act as a source of distortion by picking up capacitive noise. However, if necessary TP08 cable can be extended. Done properly, the sensor signal, although small, will not degrade, because the sensor impedance is very low.

Cable and connection specifications are summarised below.

Cable	8-wire shielded, copper core
Core resistance	0.1 Ω /m or lower
Outer diameter	(preferred) 5 mm
Outer sheet	(preferred) Teflon. Other materials like PVC and polyurethane are also applicable, depending on the application.
Connection	It is essential that the connection does not generate fluctuations in the sensor signal, and that there is no heater current flowing away. Either solder the new cable core and shield to the original sensor cable, and make a semi-waterproof connection, or use gold plated waterproof connectors. In both cases it is recommended to have significant thermal mass, preferably well-conducting, to make the joints thermally stable. Please mind that zero



	offsets do not affect the measurement as long as they are stable during the measurement heating cycle.
--	--

Table 8.9.1 *Specifications for cable extension of TP08*

The connectors that are used by Hukseflux for TP08 are manufactured by WW Fischer. In order to protect the TP08 cable, the cable is first covered by a sleeve. The sleeve typically is installed by thermal shrinkage.

Type	Code
Normal male connector to TP02 cable	S 104 A055-130 with internal part E3 104.2/6.7 + B
Normal female chassis part	DEE 104 A055-130 with 105.680 grounding washer (for soldering shield) and possibly with 104.551 spacer 6 mm (for attachment to a thin wall)
Female connector for extension cable	K 104 A055-130 with internal part E3 104.2/6.7 + B

Table 8.9.2 *Connectors for use with TP08. Please note that the TP08 cable must be covered with a sleeve for protection.*

8.10 Appendix on comparing 1-needle to 2-needle techniques

An alternative to the single needle of TP08 are systems using two needles. Both principles / systems have been used in various scientific experiments. Here is a comparison.

	1 needle (TP08)	2 needle
Measurements	Thermal conductivity only	Thermal conductivity and thermal diffusivity
Accuracy	Thermal conductivity: +/- (3%+0.02 W/mK) @ 20 °C	Thermal conductivity: unspecified, typically lower than single needle because of sensor base is in the thermal flow field. Thermal diffusivity: unspecified, typically +/- 30% attainable only with dedicated signal processing





Reliability of the measurement	Insensitive to bending. Reliable with proper data review.	The thermal diffusivity measurement is sensitive to bending because the distance between the needles is a critical parameter. Data review does not provide a fail safe check.
Suitability for repeated insertion into various media	Suitable	Not recommended because of the vulnerability of the needles.
Long term stability	Good provided that the sensor has a sealed construction	Undetermined because of possible bending of the needle.
Standardisation	Standardised by ASTM	Not standardised
Measurement range	0.1 to 6 W/mK	Typically 0.1 to 2 W/mK. This is too low for general soil analysis, reasonable for foodstuff.
Data processing	Relatively simple analysis of the slope of the curve versus $\ln(t)$. Can be performed in any spreadsheet.	Thermal diffusivity analysis cannot be expected to be accurate without dedicated processing.

Table 8.10.1 Comparison of one-needle (like TP08 or TP02) to two needle techniques.

8.11 Appendix on trouble shooting

This paragraph contains information that can be used to make a diagnosis whenever the TP08 does not function.

It is recommended to start any kind of trouble shooting with a simple check of the sensor and heater impedance, and a check to see if the thermocouples give a signal.

This test is described in the chapter on putting TP08 into operation. We now have confirmed that the connections are OK and that the sensor is still functioning.

If this check does not produce any outcome, proceed to the next table.





No signal from the sensor	Check the sensor impedance as in the chapter on putting the TP08 into operation.
	Check the MCU by applying an artificially generated voltage to the input. Preferably a millivolt generator is used for this purpose.
	Check the heater connection.
	Check the heater impedance.
	Check the functionality of the heater by putting it on. A simple 1.5 V battery can be used. When it is on, check the sensor output.
	Check the sensor connection / wiring.
Signal too high or too low	Check the MCU by applying an artificially generated voltage to the input. Preferably a millivolt generator is used for this purpose.
	Check the zero level of the data acquisition system by putting a 50 ohm resistor in place of the sensor. The data acquisition system should read less than 20 microvolt and be stable within 5 microvolt. Now put the heater on with still the resistor and not the sensor connected. The signal should not react to this by more than 10 microvolt. If there is a larger reaction, there is a ground loop from the heater to the sensor. Check the electrical connection.
	Check if the data acquisition system has sufficient sensitivity. This should be in the microvolt range.
Signal shows unexpected variations	Check is there are no large currents in your system which can cause a ground loop. If these are there, switch them off, and see if any of these is causing the disturbance.
	Check if the probe position is fixed.
	Check if the connection between medium and probe is tight.
	Check the surroundings for large sources of electromagnetic radiation. Radar installations, microwave emitters, etc.
	Inspect the sensor itself.

Table 8.11.1 Extensive checklist for trouble shooting.





8.12 Appendix on quality assurance

During the measurement a number of checks can be done to verify if the measurement conditions were good.

The suggested checks are as follows (units as in the list of symbols):

$ABS\{(Q_h - Q_{2h}) / Q_{2h}\} < 0.5\%$ Check of the power stability.

$ABS(\Delta T_{0.5h} - \Delta T_h) < 0.05 ABS(\Delta T_{1.5h} - \Delta T_{2h})$ Check if the temperature gradient before the experiment is not too large compared to the temperature gradient during the measurement.

$T_{2h} > T_{1.8h} > T_{1.7h} \dots > T_h$ Check if the signal is monotonously rising.

$0.25 < T_{2h} - T_h < 2.5$ Check if the total temperature rise is not too large or small.

$0.1 < \lambda < 6$ This is a range check of the thermal conductivity.

$50 < h < 1000$ Check if the heating time is not too short or too long

Check on the input parameters like sample number, operator number etc





8.13 Appendix with measurement form / test report

For an example of a measurement from, see below

Thermal Conductivity Test Report

Experiment

Experiment date	D/M/Y
Experiment time	Hour/min
Check instrument date & time	OK
Experiment number	---
Instrumentation identifier or serial numbers	---

Sample

Sample number	---
Location identifier/ co-ordinates	---
Measurement / sample depth	Cm below surface
Soil physical description (sand, clay, silt, homogeneity, any other comment)	
Water content	Vol%
Density	Kg/m ³
Dry density	Kg/m ³

Results

Thermal Conductivity (W/mK)	W/mK
Standard deviation (W/mK)	W/mK
Check Standard Deviation < 10% Thermal Conductivity	OK
Filename for storage	
Warnings / Further analysis required	Yes / No

Signature
Name
Date





8.14 Appendix on literature references

The following literature gives a good overview of the Non-Steady-State Probe measurement technique.

Application of Parameter Estimation Techniques to Thermal Conductivity Probe Data Reduction, Koski, J. A. , McVey, D. F., Thermal Conductivity 17, Plenum Press New York, 1986, pages 587-600.

Determination of the Thermal Conductivity of Moist Porous Materials near The Freezing Point, Van Haneghem, I. A., Van Loon, W. K. P., Boshoven, H. P. A., High Temperatures-High Pressures, 1991, Volume 23, pages 157-162.

Error Analysis of the Heat Pulse Probe for Measuring Soil Volumetric Heat Capacity, Kluitenberg, G. J., Ham, J. M., Bristow, K. L., 1993, Soil Science Society of America Journal 57:1444-1451

Standard Test Method for Determination of Thermal Conductivity of Soil and Soft Rock by Thermal Needle Probe Procedure, American Society for Testing and Materials, D 5334 - 92, 1992.

Standard Test Method for Thermal Conductivity of Plastics by Means of a Transient Line Source Technique, American Society for Testing and Materials, D 5930 - 97, 1997.





8.15 CE Declaration of Conformity

According to EC guidelines 89/336/EEC, 73/23/EEC and 93/68/EEC

We: Hukseflux Thermal Sensors

Declare that the product: TP08

Is in conformity with the following standards:

Emissions: Radiated: EN 55022: 1987 Class A
Conducted: EN 55022: 1987 Class B

Immunity: ESD IEC 801-2; 1984 8kV air discharge
RF IEC 808-3; 1984 3 V/m, 27-500 MHz
EFT IEC 801-4; 1988 1 kV mains, 500V other

Delft
March 2001

