

HEXAGON-IMAGING-PAM

Chlorophyll Fluorometer

Instrument Description and Information for Users

2.176 / 07.022

HEXAGON-Imaging.doc

© Heinz Walz GmbH, 2023

Heinz Walz GmbH • Eichenring 6 • 91090 Effeltrich • Germany
Phone +49-(0)9133/7765-0 • Fax +49-(0)9133/5395
E-mail info@walz.com • Internet www.walz.com

CONTENTS

1	Safety instructions.....	1
1.1	General safety instructions.....	1
1.2	Special safety instructions.....	2
2	Introduction.....	3
3	Components of the HEXAGON-PAM.....	5
3.1	Setting up the HEAXGON-IMAGING-PAM.....	10
3.2	Use of the base plate	10
3.3	Mounting the side screens as glare protection	11
3.4	Pot Holder IMAG-HEX/PH.....	12
3.5	Connecting the Cables	12
3.6	Software installation	13
3.6.1	Installation and Starting of ImagingWin.....	13
3.6.2	Re-installation of the camera driver.....	15
3.6.3	First steps and examples of routine measurements.....	15
4	ImagingWin	33
5	IMAGINGWIN - System Operation.....	37
5.1	Definition of New Record.....	37
5.1.1	Fo, Fm.....	37
5.1.2	New Record	38
5.1.3	Measure.....	39
5.2	Functions applying to View mode	40
5.3	Light controls.....	42
6	IMAGINGWIN - Tabs.....	46
6.1	Image-window	46
6.1.1	Different types of images.....	47
6.1.1.1	Current fluorescence yield, Ft	47
6.1.1.2	Dark fluorescence yield, Fo	48
6.1.1.3	Fluorescence yield, F.....	48

CONTENTS

6.1.1.4	Maximal fluorescence yield, F_m	48
6.1.1.5	Maximum fluorescence yield, F_m'	49
6.1.1.6	Maximum PS II quantum yield, F_v/F_m	49
6.1.1.7	Effective PS II quantum Yield, $Y(II)$	50
6.1.1.8	Quantum yield of regulated energy dissipation, Y(NPQ).....	52
6.1.1.9	Quantum yield of non-regulated energy dissipation, Y(NO).....	53
6.1.1.10	Apparent rate of photosynthesis, PS/50.....	54
6.1.1.11	Nonphotochemical quenching, NPQ/4.....	55
6.1.1.12	Coefficient of nonphotochemical quenching, q_N	55
6.1.1.13	Coefficient of photochemical quenching, q_P	57
6.1.1.14	Coefficient of photochemical quenching, q_L	58
6.1.1.15	Inhibition, Inh.	58
6.1.2	Image capture and analysis	59
6.1.2.1	Area of Interest, AOI.....	60
6.1.2.1.1	Transfer of AOIs between measurements and datasets.....	63
6.1.2.2	Select: Fluorescence or Live Video.....	64
6.1.2.3	Zoom.....	66
6.1.2.4	Cursor	67
6.1.2.5	Analysis	67
6.2	Kinetics window.....	70
6.3	Light Curve window.....	78
6.4	Report window	84
6.5	Settings window	87
6.5.1	Light paramters	88
6.5.2	Gain and Damping	91
6.5.3	Slow Induction paramter.....	93

6.5.4	Image Correction	93
6.5.5	Image Transformation.....	96
6.5.6	Display parameters	96
6.5.7	Go Speed.....	98
6.5.8	PS Limit.....	98
6.5.9	Inh. Ref. AOI.....	99
6.5.10	Yield Filter.....	99
6.5.11	F Factor.....	100
6.5.12	Reset Default Settings, Open or Save User Settings.	103
7	IMAGINGWIN - Menu Bar	104
7.1	File	104
7.1.1	Transfer FoFm	104
7.1.2	Using Skript files - Load Script/Run Script.....	104
7.1.3	Exit.....	114
7.2	Options Menu.....	114
7.2.1	Ruler	114
7.2.2	Scale.....	115
7.2.3	Mean over AOI.....	115
7.2.4	Define AOI-array geometry.....	118
7.2.5	Create AOI array:.....	118
7.3	Al-List.....	120
7.3.1	LED currents / PAR values.....	121
7.3.2	Light Calibration.....	122
7.4	Recalc.....	123
7.5	Transect.....	125
8	Troubleshooting	128
8.1	Error Network Settings	128
8.2	No Connection with the Computer	129

CONTENTS

9	List of key commands	130
10	Technical specifications HEXAGON-PAM.....	131
10.1	HEXAGON-PAM	131
10.2	Windows Software ImagingWin.....	132
11	Manufacturer's Guarantee	134
11.1	Conditions	134
11.2	Instructions.....	135
11.3	Applicable law.....	136

1 Safety instructions

1.1 General safety instructions

1. Read the safety instructions and the operating instructions first.
2. Pay attention to all the safety warnings.
3. Keep the device away from water or high moisture areas.
4. Keep the device away from dust, sand and dirt.
5. Always ensure there is sufficient ventilation.
6. Do not put the device anywhere near sources of heat.
7. Connect the device only to the power source indicated in the operating instructions or on the device.
8. This product can be damaged by some volatile cleaning agents. Clean the device only according to the manufacturer's recommendations.
9. If the device is not in use, remove the mains plug from the socket.
10. Ensure that no liquids or other foreign bodies can find their way inside the device.
11. Keep shipping material – poor packaging of the instrument may cause damage during shipping
12. The device should only be repaired by qualified personnel.

1.2 Special safety instructions

The IMAGING-PAM systems are a highly sensitive research instruments which should be used only for research purposes, as specified in this manual. Please follow the instructions of this manual in order to avoid potential harm to the user and damage to the instrument.

The IMAGING-PAM employs strong blue light for excitation of chlorophyll fluorescence, for driving photosynthetic electron transport and for transient saturation of photosynthetic energy conversion (Saturation Pulse method). To avoid harm to your eyes, please avoid looking directly into this light, particularly during actinic illumination phases and saturating pulses.

2 Introduction

Any Walz IMAGING-PAM Chlorophyll Fluorometer is a specialized instrument for the study of spatial heterogeneities in PSII activity. The HEXAGON-IMAGING-PAM has a maximum imaging area of 20 x 24 cm.

Like all PAM fluorometers, the HEXAGON-IMAGING-PAM applies pulse-amplitude-modulated measuring light to determine the chlorophyll fluorescence yield. The instrument uses the same LEDs for the generation of pulse-modulated measuring light, but also for actinic illumination (AL), driving photosynthesis and for Saturation Pulses (SP), transiently saturating energy conversion in Photo- system II (PS II) reaction centers.

The saturation pulse method is a non-destructive and non-invasive method for analyzing the photosynthetic performance of plants and other photosynthetic organisms. It allows the assessment of the quantum yield of energy conversion in PS II reaction centers.

The quantum yield is affected by numerous intrinsic and environmental parameters, like the physiological health of the sample, light conditions, and various stress factors. Since the introduction of PAM fluorometry in 1985, many articles have been published on practical applications of this method in many fields of plant science. With the HEXAGON-IMAGING-PAM the characteristic fluorescence levels F_0 , F_0' , F_m and F_m' can be assessed, and quenching coefficients derived. In addition, the PS II quantum yield F_v/F_m (or $\Delta F/F_m'$) can be determined and such data are often derived from Induction Curves and Light Saturation Curves.

The information provided by chlorophyll fluorescence imaging, which can only be obtained using imaging instruments is

the detection of spatial heterogeneities in fluorescence parameters reflecting physiological heterogeneities.

It is known, that even physiologically healthy leaves are “patchy” with respect to stomatal opening. Furthermore, stress-induced limitations, which eventually will lead to damage, are in most cases not evenly distributed over the whole leaf area. Chlorophyll-fluorescence imaging can serve as a convenient tool for early detection of stress-induced damage. Hence, favorite fields of application of fluorescence imaging are plant stress physiology and plant pathology.

An outstanding feature of the Imaging PAM fluorometers that distinguishes it from conventional PAM fluorometers is the ability to examine multiple samples simultaneously under identical conditions. For this application the HEXAGON-IMAGING-PAM is particularly well suited, e.g., for the screening of mutants in plant molecular biology and for the assessment of samples in, e.g., 96-well plates. For the HEXAGON-IMAGING-PAM a fourfold increase of the sample area has been realized.

In the HEXAGON-IMAGING-PAM, 66 high-power LEDs ensure extremely homogeneous illumination of the measuring field with the highest light yields at the same time.

This manual provides essential information on the components of the HEXAGON-IMAGING-PAM and on the ImagingWin software.

3 Components of the HEXAGON-PAM

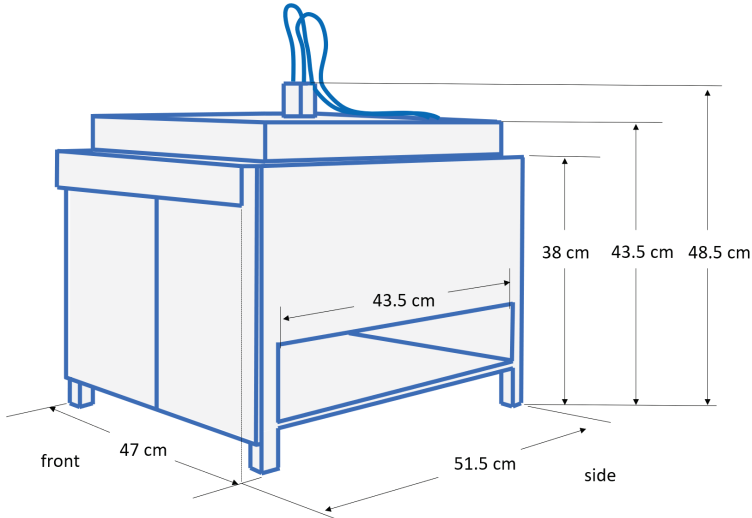

Fig. 1 HEXAGON-IMAGING-PAM basic device - schematic drawing and dimensions

The HEXAGON-PAM is a highly integrated instrument once the camera is installed. There is the instrument itself, its power supply and the control PC with accessories.

The HEXAGON-PAM is with its of 47 x 51.5 x 48.5 cm (LBH) and 18.5 kg considerably larger and heavier than e.g. the MAXI-IMAGING-PAM. If the user decides to use a NUC PC, which is offered as



Fig. 2 NUC Windows PC mounted at the side of the HEXAGON-IMAGING-PAM

accessory, the computer can become an integral part of the instrument (Fig. 2). The mounting bracket for the NUC-PC (IMAG-HEX/PC) is always supplied with the basic unit.

For the best view of the images, it is necessary to use a WQHD monitor since with a resolution of 2560 x 1440 pixels it enables the user to see the calculated images in their unscaled resolution.

Before starting ImagingWin for the first time, please make sure that the display resolution is at native 2560x1440 px (WQHD resolution) and the scaling is set to 100%.

After connecting to a new monitor, the operating system will in some cases also switch to a higher scaling factor once. After a single adjustment, however, it usually retains the setting.



Fig. 3 HEXAGON-IMAGING-PAM seen from the side. The upper bottom plate is taken out. To prevent light from escaping from the side during measurement, the side flaps supplied should be fitted (not shown).

Earlier Walz Imaging instruments did not have far-red LEDs, because they interfere too strongly with the detection of the fluorescence detection.

In the HEXAGON-PAM this problem was solved allowing the experimental determination of F_0' and allows the user to carry out State Transition experiments. The LED-panels have the form of hexagons. A total of 78 powerful Cree high

power LEDs (peak emission wavelength at 451 nm, 600 W) are arranged in the LED panel. With this panel actinic light intensities of up to 2000 $\mu\text{mol photons m}^{-2} \text{s}^{-1}$ and saturation pulses of 4100 $\mu\text{mol photons m}^{-2} \text{s}^{-1}$ can be applied.

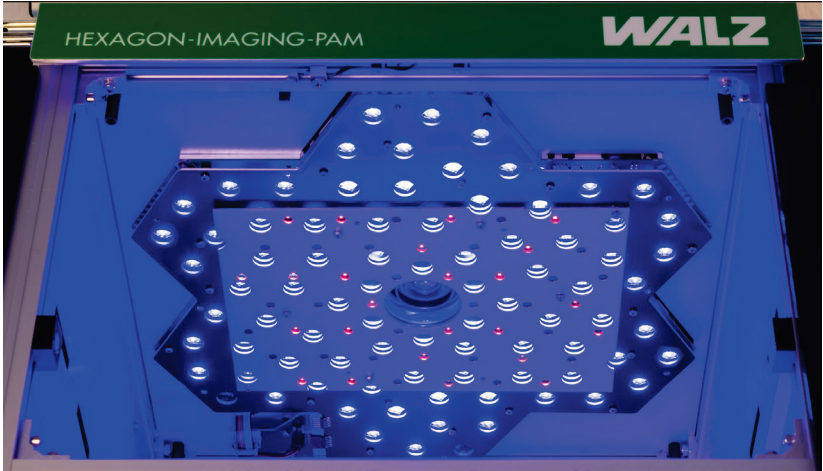
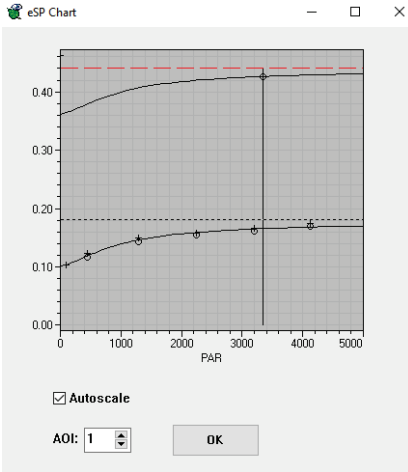

Fig. 4 LED panel seen from below. Consisting of hexagon shaped subunits which 78 blue LEDs and two circles of far-red LEDs

Much attention has been paid to the cooling of the LEDs to minimize temperature effects on the measurements.



In many cases $4100 \mu\text{mol photons m}^{-2} \text{s}^{-1}$ will be enough to reach F_m' . However, the instrument offers an alternative approach based on the idea that the ratio between photochemical (I_1 -max level) and thermal phase is fixed for a particular sample. The I_1 -max level is determined on the basis of 2

ms pulses of increasing intensity followed by a fit of the obtained intensities. The obtained graph is then shifted up to a level defined by a single long pulse of strong light.

The HEXAGON-IMAGING-PAM can be used to measure a variety of sample types. In Fig. 3 an example of the measurement of a plant tray is given. Alternatively, potted plants, microwell plates or detached leaves can be measured.

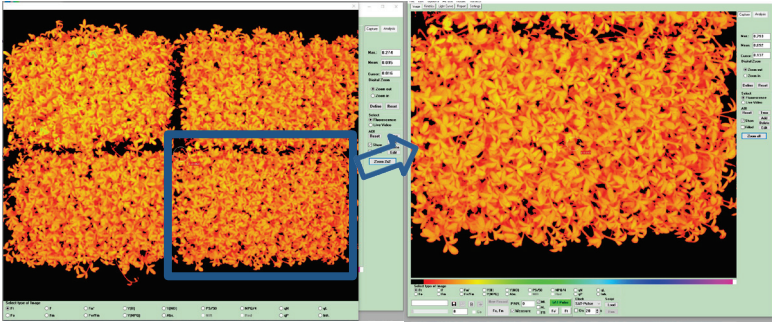

Fig. 5 2 x 2 digital Zoom without loss of resolution

In above image another technical feature of the HEXAGON-IMAGING-PAM instrument is demonstrated. By switching from 2x2 binning to 1x1 binning the instrument can zoom in on a quarter of the measured surface. The gain is automatically adjusted so that the F-values are stable.

Notes: **Note: All cables should be connected prior to switching on the Control Unit, the separate POWER-SUPPLY and the starting of the PC.**



Generally, always first switch off the external POWER-SUPPLY before detaching cables.

Never change the voltage of the power supply.

Follow the instructions in the following chapters for set-up and safe operation.

3.1 Setting up the HEXAGON-IMAGING-PAM

The HEXAGON-IMAGING-PAM base unit is quick to assemble and very easy to use. The following sections explain how to assemble the system and install the software on the PC. In addition, some simple measurements are described to help the user become familiar with the instrument.

3.2 Use of the base plate



Fig. 6 the supplied base plate can be used in various combinations in the HEXAGON-IMAGING-PAM.

On the left side of the Fig. 6, the base plate is inserted into the imaging PAM at the highest position from the front through the sliding doors. The plate has several holes that are designed to hold the plate in position when placed on the rear pegs. In this position the measurement of detached leaves or other flat samples is possible. A supplied plate covered with a non-fluorescent PU foam can serve as a background that also helps to position the samples. The black PU foam is quite robust and can be cleaned under running water if dirty.

For higher specimens, such as small seedlings in planting trays, the bottom plate can be inserted into the HEXAGON-IMAGING-PAM from the side (shown in Fig. 6 on the right side).

To guide the base plate at the correct height, there are angles at the front and rear of the housing, the height of which can be adjusted to suit specific needs. Since a lot of light can get out of the PAM by inserting it sideways or even using the device without a base plate, it is strongly recommended to use the side screens in these cases. Please find more information on how to use these screens in the following section 3.3

3.3 Mounting the side screens as glare protection

If the HEXAGON-IMAGING-PAM is used in a more open configuration, where a lot of light may leave the PAM housing, it is recommended that the side screens and glare shields are fitted.

Depending on the configuration in which the unit is to be used, the screens can be mounted in one or the other variant.



Fig. 7 Use of the supplied screens to protect the user from reflections. On the left side the instrument is completely closed and can be used with the base plate in the highest position or without the baseplate for potted plants. On the right side the user is still protected from direct glare but plant trays can still be inserted from the side.

3.4 Pot Holder IMAG-HEX/PH



The optional article IMAG-HEX/PH is a positioning tool for plant pots. The precise repositioning of potted plants in repeated measurements is made easier with the

colorless Perspex frames. The rack, taking up the pot holder frames is mounted inside the HEXAGON measuring chamber and can stay mounted even when the base plate is mounted on the highest position or sliding in from the side. The frames are designed for the following flower pots: VQF 7x7x6,5 as square pot (with 6 pots per measurement) and MPB 6 as round version to get 9 into the HEXAGON as shown in the image above.

The pots are manufactured by Poepplmann ([Pöppelmann TEKU® \(poepplmann.com\)](http://poepplmann.com)).

With the article two frames for each pot size are included.

3.5 Connecting the Cables

1) Camera cable between the CCD Camera and the IMAG-HEX (Hirose I/O cable) cable.

The plug is polarized for correct insertion by a straight push-in movement. It has a built-in lock release mechanism allowing quick disconnection by simply pulling on the plug release collar.

2) GigE Ethernet cable between Camera and the PC (RJ45 type) connects the camera with the control computer.

3) LED-Array cable connecting to the POWER-SUPPLY with the red plug in the red (+) socket and the black plug in the black (-) socket.

Please Note: Connect all cables **before** switching on the POWER-SUPPLY

3.6 Software installation

The ImagingWin software and drivers required to operate the HEXAGON-IMAGING-PAM are already installed if the optional NUC PC (IMAG-HEX/PC) was purchased with the machine. If the designated control computer is purchased separately, the user can install the required software as described in the following subsections.

Please do not forget to check if the correct light list is installed. When purchasing a computer together with the HEXAGON-IMAGING-PAM the PAR list is already installed. Users with alternative control computers will get a USB stick together with the instrument which carries a copy of the current PAR list (LRLJxxxx.par). To learn more about handling this file please refer to section 7.3 from page 120 on.

3.6.1 Installation and Starting of ImagingWin

The ImagingWinGigE software is supplied with the instrument on a USB stick or can be downloaded from the Walz homepage. (www.walz.com)

To install ImagingWin, the USB stick is inserted into a USB port of the PC that controls the HEXAGON-IMAGING-PAM.

To install the software, the setup file must be copied to the control computer and run manually. As part of the installation process, a program icon (ImagingWin) and a link to the ImagingWinGigE folder are automatically placed on the desktop.

The installer will guide you through the installation process and will also recommend a drive path. Please accept the suggested drive path: C:\ImagingPamGigE.

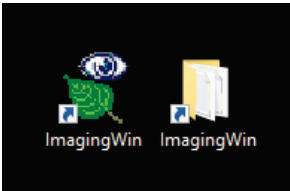

The ImagingWin folder contains all the files required to operate the HEXAGON-IMAGING-PAM, as well as the data directories for the different types of measuring heads.

Updates of the ImagingWinGigE software in the form of setup files can be downloaded from the Walz website (www.walz.com) under DOWNLOADS => Chl Fluorescence & P700 and then go to IMAGING-PAM *M-series* and click on ImagingWin Software (please check that you have the correct software version as the normal ImagingWin software versions for MAXI, MINI or MICROSCOPY-IMAGING-PAM will not work with the HEXAGON-IMAGING system in its current state).

Start the update process by double-clicking the EXE file to start the installation process. Data directories and all system settings will be unaffected by the update. In some cases, clicking through the update log may result in warnings. These can be ignored by clicking 'Continue Anyway'. The installer will automatically set up the required camera drivers.

Once installed, the software can be launched by clicking on the ImagingWin desktop icon.

It may happen that a computer on which the ImagingWin software is to be installed for the first time, receives an error message. It

may happen that a computer on which the ImagingWin software is to be installed for the first time receives an error message. To solve this problem, please refer to the Troubleshooting chapter pp 128.

3.6.2 Re-installation of the camera driver

It may happen that divers interfere with each other so that after the installation of a new software the camera driver of the HEXAGON-IMAGING-PAM got lost and no connection is possible. For these events the easiest way to reconnect it is to reinstall the entire ImagingWinGigE software. It is also a good idea to check the Walz website to see if a newer version of the software is available.

3.6.3 First steps and examples of routine measurements

After the HEXAGON-IMAGING-PAM has been set up (see sections 3.5 and 3.6) and switched on, first measurements can be carried out to familiarize yourself with the HEXAGON-IMAGING-PAM.

Before starting the software, the POWER-SUPPLY should be switched on using the green main switch on the left-hand side of the front panel. A (closed) padlock symbol on the display of the POWER-SUPPLY indicates that the operating voltage setting is locked; 48 V is the correct value. If no current is flowing, the amperage (A) on the display will remain at zero.

To avoid damage to the HEXAGON-IMAGING-PAM, the POWER-SUPPLY must only be used with 48 V as the set value and must be always kept in the locked state!



A green light on the right Power button indicates that the HEXAGON-IMAGING-PAM is receiving power.

The six fans on the top of the imaging unit should now be actively (rotating).

Start the ImagingWin software by double-clicking the desktop icon and the image window of the HEXAGON-IMAGING-PAM will open. Start the ImagingWin software by double-clicking the desktop icon and the image window of the HEXAGON-IMAGING-PAM will open.

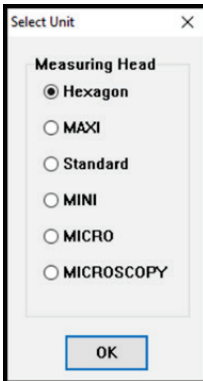

A pop-up menu, as shown in the figure on the left, will only appear in View mode (when the software is opened without being connected to the HEXAGON-IMAGING-PAM).

This will also happen if the software is not connected to the imaging device - in this case, check that the power supply is connected and switched on. Please note that it takes a few seconds for the camera to appear as a network device in the computer.

When the software starts up and communication with the HEXAGON-IMAGING-PAM instrument is established, the measuring light is automatically switched on so that a sample, placed in the measuring area, can directly be seen with the settings that were used the last time the PAM instrument was used.

Appearance of the ImagingWin software directly after start-up:

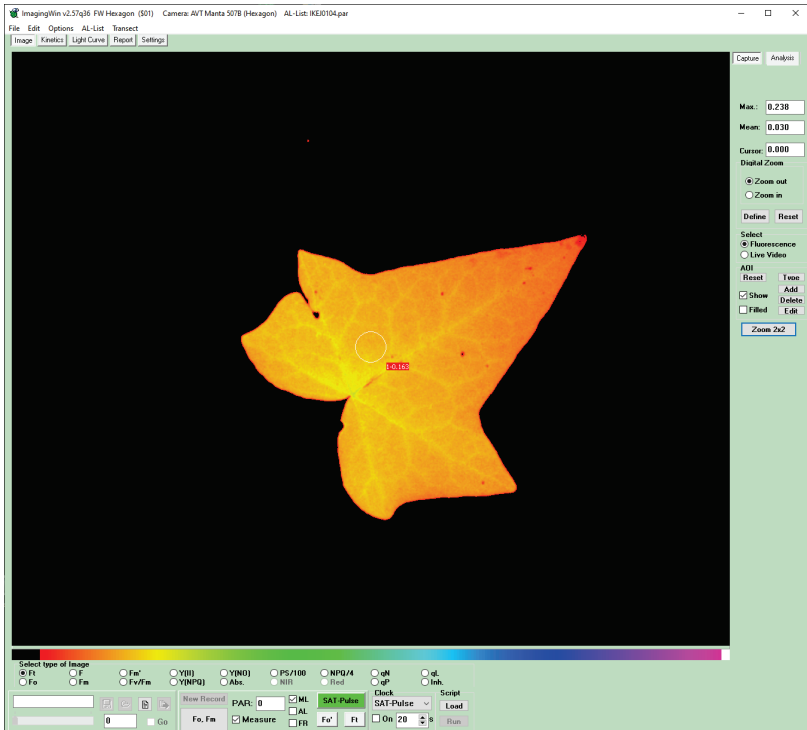
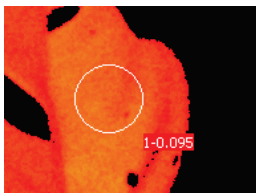

Fig. 8: Starting window of ImagingWin with HEXAGON-IMAGING-PAM connected and switched on (here: measure mode active). For details on the software resume with section 4.



By default, a circular Area of Interest (AOI) is defined in the center of the screen: an Area of Interest. The value of all pixels within this area are averaged and this mean value is shown in the small red flag next to the AOI (the consecutive number of the set AOI is shown on the left side of the flag on the right side the mean value for the selected parameter is displayed). This number is also used

later in the Report tab. The value shown corresponds to the selected parameter marked below the image.

Immediately after starting the software in the measure mode, it is the value of the Ft parameter.

Additional AOIs can be added and placed by the user by clicking 'Add' in the AOI box (see Fig. 9). The first AOI is numbered 1 and each additional AOI is numbered in ascending order.

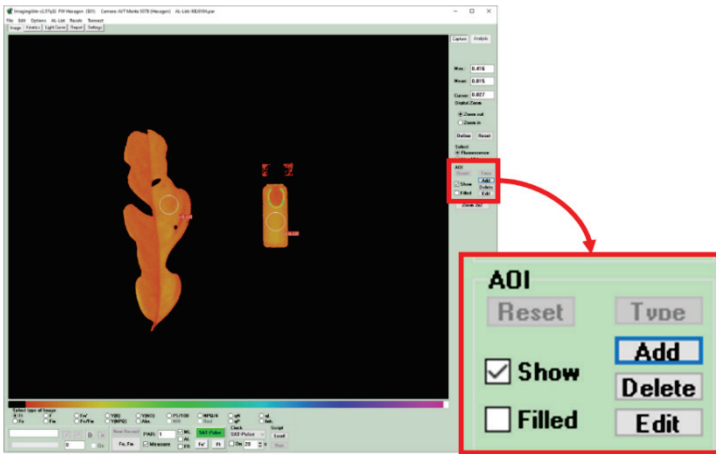

Fig. 9: Magnification of the AOI type section of the starting window

The default AOI shape is "Circle"; rectangular, polygonal shapes can also be selected from the pop-up menu that appears when "Type" is clicked in the AOI definition box. A new AOI type is **Leaf**.

Only the circular AOIs can be moved or edited by clicking Edit and then clicking and moving or resizing the target AOI.

To change the size of a circular AOI, click Edit in the AOI definition box shown in Fig. 9 and then the target AOI. Then type '+' (for larger) or '-' (for smaller) one or more times to incrementally change the AOI size.

The first AOI is numbered 1 and each subsequent AOI is numbered in ascending order.

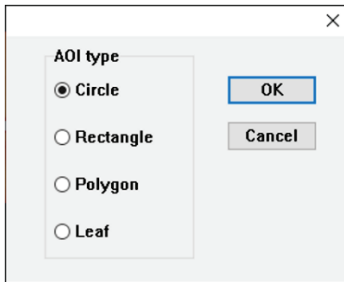

To draw a rectangle, simply select the Rectangle function and click Add. You can then left click to set the top left corner of the rectangle, then move the cursor to the bottom right corner of the rectangle and click again.

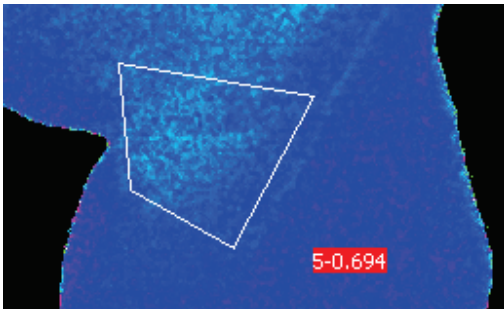

Fig. 10 AOI in polygon type (fifth AOI with a value of 0.694 for the parameter selected below the image window.

Selecting 'Polygon' and then clicking 'Add' requires the user to draw a line segment, click, draw the next segment and so on to create the desired shape for the new AOI. By double-clicking at the end of the last

segment, the software connects the start and end points to complete the polygon shape (Fig. 10). If necessary, this function can be used to draw very complex polygons by hand. There are up to 100 corner points available for each polygon that can be set.

If the samples are clearly separated by the background, the polygon function can also be replaced by the AOI type “Leaf”. This AOI type automatically finds the edges of each sample and can also contain up to 100 points. Breakthroughs or holes in samples are not considered.

The automatic "Leaf" function is equipped with a certain threshold, so that clicking on a sample area of relatively higher intensity detects a smaller area of the sample, while placing a "Leaf" AOI on an area of relatively lower intensity detects a larger area of the sample as the measurement area.

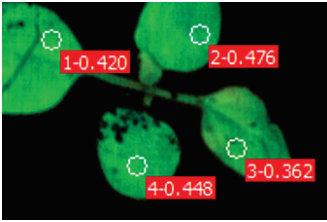

The red flags next to the AOIs contain two numbers. The first number is the AOI number, which can also be found in the legend that pops up when you click the AOI button in the upper right corner of

the **Kinetics** or **Light Curve** window (Fig. 11).

The second number starts with a zero and represents with three decimal places the value of the parameter chosen for the display (see Fig. 13)

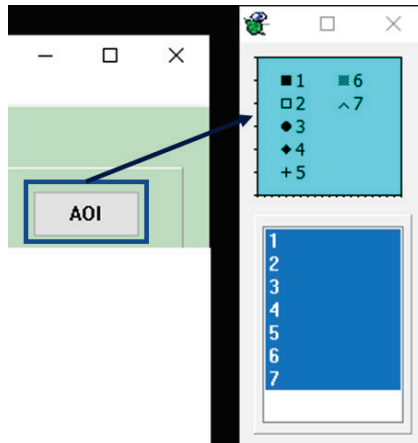

Fig. 11 AOI Legend showing up on clicking the AOI-button. Each AOI is assigned a symbol that is used in kinetic graphs.

At the bottom of the image area the **false color code bar** is displayed, with the colors encoding for numerical values between

0 (corresponding to black at the left edge) and 1 (corresponding to purple at the right edge).

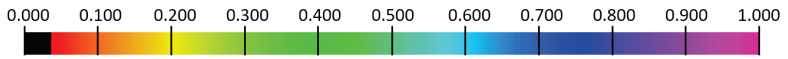

Fig. 12 Standard Lookup table (LUT) that is used by the ImagingWin software for false color display.

So far, the HEXAGON-IMAGING-PAM monitored the fluorescence yield, but no actual saturation pulse measurement was made. With the HEXAGON-IMAGING-PAM, just as with most other PAM fluorometers, “measurement” means the assessment of photosynthetic parameters by the fluorescence quenching analysis with the help of a saturating light pulse (**Saturation Pulse**).

For the determination of so-called **quenching coefficients**, measurements of the minimal and maximal fluorescence yield of a dark-acclimated sample are needed (section 6.1.1.7 page 50).

Often a long dark acclimatization is not necessary. In most cases, a few minutes of acclimatization to low room light is sufficient ($5\text{-}10 \mu\text{mol quanta m}^{-2} \text{s}^{-1}$). Algae already grown under such low light conditions are an exception and may require darker conditions for dark acclimatization.

Actinic light and saturation pulses are deactivated for safety reasons when the sliding doors of the unit are opened (a red marked sat pulse button indicates that the doors are not properly closed). However, the measuring light and the FR light remain on to facilitate sample alignment and it is therefore recommended to wear protective goggles when looking into the measuring light frequently.

The “dark fluorescence parameters” can be assessed by an **F_o, F_m** measurement.

The corresponding button is found at the bottom of the screen, together with various other function buttons needed for the experiments.

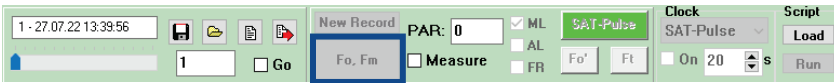

After the initial determination of F_o , F_m , the parameter F_v/F_m (below the image window) can be selected to view the result.

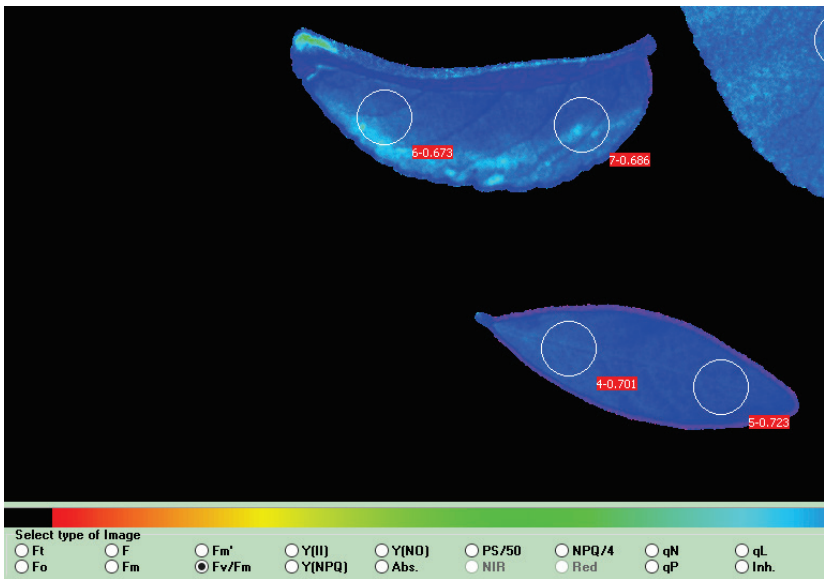

Fig. 13: screenshot of the Image window following F_o , F_m determination of three late summer leaves with the F_v/F_m image being selected.

In Fig. 13 the Image window following F_o , F_m -determination is shown, when the **F_v/F_m -parameter image** is selected.

F_v/F_m reflects the maximum PS II quantum yield of a dark-acclimated sample. For the given leaf sample, F_v/F_m is quite homogeneously distributed over the whole leaf. Note that after the F_o , F_m determination, the **F_o , F_m button** is inactive - the *New Record* button is accessible instead. For each record only a single F_o , F_m measurement can be saved as reference.

The reference F_o , F_m is subsequently used for calculations of quenching parameters and since in most cases no higher values than the initial F_m can be expected during experiments, the F_o , F_m is also used for the normalization of following saturating flashes

and their values. Pressing the “New Record” button resets the scaling and starts a measuring sequence from the beginning.

For getting acquainted to the software and the plants’ reaction, the user can apply a few saturation pulses and see how the images of the different parameters (e.g. F, Fm’, Yield, qP and qN) change with the length and intensity of a pre-illumination.

When the sample is illuminated, the **effective quantum yield** (YII) section 6.1.1.7 page 50) decreases, due to the partial closure of the population of PS II reaction centers (decreases photochemical quenching) and energy dissipation as heat increases (increase of non-photochemical quenching).

Actinic illumination can be turned on manually by checking the **AL box (marked red in the image below)**. The **PAR box** shows the PAR-value of the **incident light** according to the PAR list of the instrument.

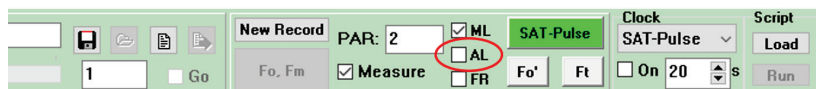

For assessment of fluorescence parameters during actinic illumination, a Saturation Pulse can be applied using the SAT-Pulse button. Fig. 14 shows an image of the effective PS II quantum yield Y(II), measured with the help of a Saturation Pulse, applied after 2 min illumination at $81 \mu\text{mol quanta m}^{-2} \text{s}^{-1}$.

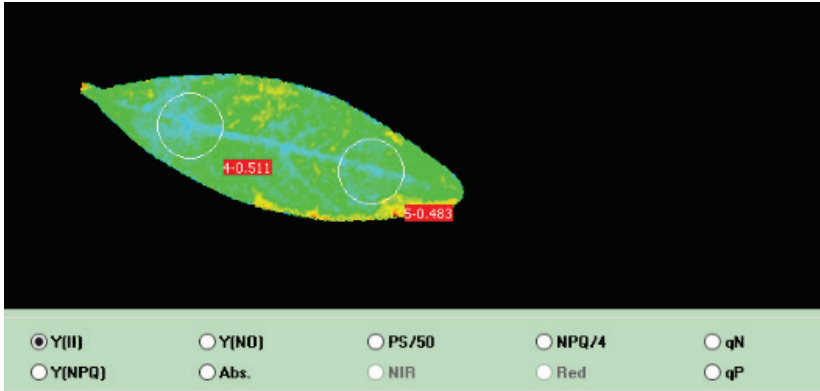

Fig. 14: Y(II) image assessed after 2 min illumination with $81 \mu\text{mol quanta m}^{-2} \text{s}^{-1}$

This measurement reveals some heterogeneity in the extent of the lowering of the effective PS II quantum yield *between* different parts of the leaf. In the light-acclimated state there is a balance between PS II and the Calvin-Benson cycle. This makes Y(II) sensitive to heterogeneity in stomatal opening. Consequently, the observed heterogeneity in the (effective) PS II quantum yield is much more pronounced in the light than in darkness.

Considerable heterogeneity is also displayed by non-photochemical quenching (expressed by the fluorescence parameters qN (and NPQ/4), see also section 6.1.1.12) as illustrated in Fig. 15

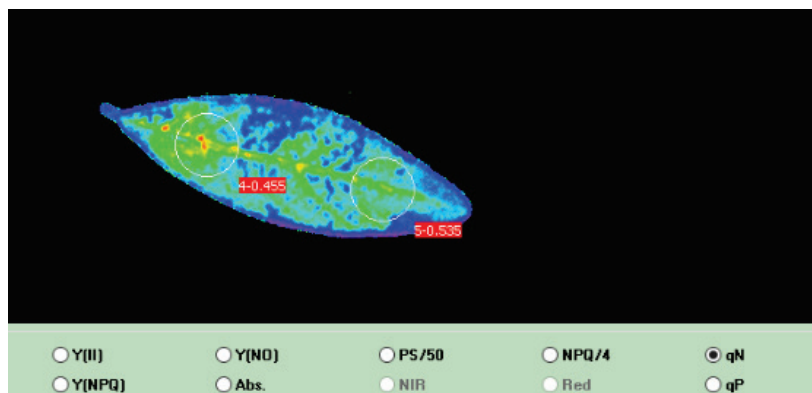

Fig. 15: Image of the coefficient of nonphotochemical quenching qN measured 2 min after onset of illumination at $81 \mu\text{mol quanta m}^{-2} \text{s}^{-1}$

Light-induced changes in fluorescence parameters are highly dynamic. When a dark-acclimated sample is illuminated, the fluorescence yield first rises and then drops again (curves measured following **dark-to-light transitions, Kautsky effect**). **Saturation Pulse quenching analysis** reveals that characteristic changes in quantum yield of PS II, $Y(II)$, and non-photochemical quenching (qN) accompany changes in the fluorescence yield. The **Kinetics-window** is there for the study of induction phenomena measured on a dark-to-light transition. It is selected by clicking the **Kinetics** button at the top of the screen. For the recording of induction kinetics at least one AOI has to be defined. Then the recording of an **Induction Curve** (select **Ind.Curve** in the dropdown menu on the right-hand side of the graphical window) can be started by clicking “Start”. The values used for an automated induction curve can be made in the settings tab of ImagingWin (AL Intensity, duration, SP Intensities see 6.5.1 page 88). Default settings are loaded after software installation so that a run can also be started without adapting settings.

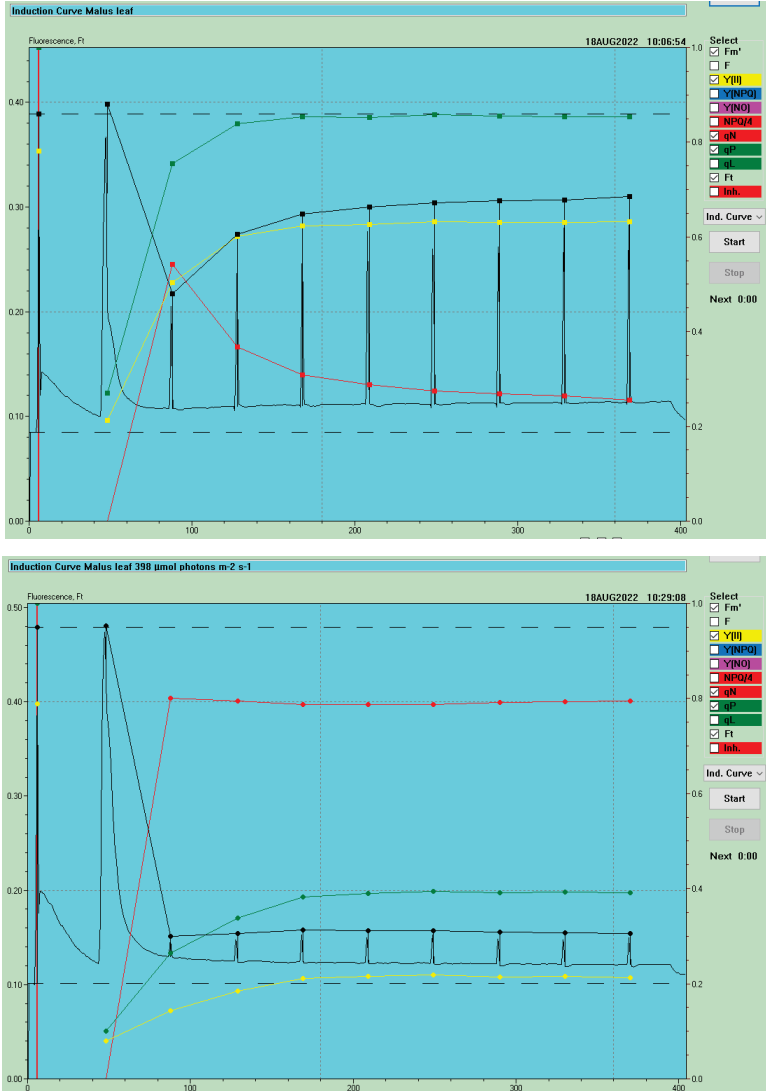

Fig. 16: Kinetics window showing Induction Curve measured at 111 and then at 398 $\mu\text{mol photons m}^{-2} \text{s}^{-1}$ (lower image). One AOI was selected, for which the averaged pixel values of F_m' , $Y(II)$, qN , qP and F_t are displayed (Selection of parameters on the right window side).

In ImagingWin the recording of an Induction Curve constitutes a **New Record**, which is first stored in the computer **buffer**. It can later be saved on the hard disk of the PC. When the recording of the Induction Curve has ended, ImagingWin quits Measure mode (the Measure check box becomes unchecked) and switches to View mode, which allows the user to inspect and analyze all recorded data.

If the recording has been ended or canceled, the device automatically switches to **View Mode** (the **Measure** check box becomes unchecked Fig. 17) and switches to **View mode**, which allows the user to inspect and analyze all recorded data.

During the recording of an Induction Curve a vast amount of data was accumulated and stored, which can be analyzed at any time after the measurement. For this reason, it is recommended to always save experimental data in the proprietary ImagingWin file format xpim which contains all important data recorded during the measurement (images, positions, sizes and corner points of AOIs and a list of valid settings).

Analysis is possible in off-line **View mode**, i.e., without the HEXAGON-IMAGING-PAM being connected to a PC. For each Saturation Pulse the images of the various fluorescence parameters are captured. These images can be viewed by returning to the **Image window**, where the desired parameter can be selected.



Fig. 17 In the view mode a slide controller for the measuring points of the experiment is available (blue highlighting) and the number of the measuring point (highlighted in red)

When the **Go** box is checked (section 9.2), the consecutive images are shown like a movie, starting with the data set corresponding to the Fo, Fm-determination. The **Go Speed** can be modified under **Settings** (click the corresponding button at the top of the window). Images can also be selected manually after deactivating Go (unchecking the Go box) and moving the dial in the blue window (right side of the figure) with the cursor towards the right. Each step represents a data set associated with a Saturating Pulse.

The current image number shown in the image window is indicated in a separate box (Fig. 16 red). In View mode the data can be stored in the form of so-called **PAM Imaging file (xpim) files** on the hard drive. Individual images can also be exported in the form of **TIFF** or **JPEG files** (section 5.2 page 40).

Dark-to-light Induction Curves give important information on various steps of the complex process of photosynthetic induction and allow the user to identify the site of a possible limitation, e.g., induced by a stress factor. The HEXAGON-IMAGING-PAM allows the user to apply this tool with high reproducibility using **pre-programmed Standard Induction Curve protocols**. The **Induction Curve parameters**, like Actinic Light Intensity, time interval between Saturation Pulses and duration of illumination can be defined by the user under **Settings**.

Another standard tool for assessment of photosynthetic parameters by Saturation Pulse quenching analysis are recordings of **Rapid Light Curves** (called **Light Curves** when the step length is long enough to approach the steady state). For the measurement of a Light Curve the user has to switch to Measure Mode and click the **Light Curve tab** above the Image window.

For the recording of a pronounced Induction Curve, it is important to dark acclimate the sample. For the recording of a Light Curve,

on the other hand, it is useful if induction effects are eliminated by pre-illuminating the sample.

Therefore, Light Curves can be best measured shortly after an Induction Curve measured on the same sample (or following for example a 2 min pre-illumination with approximately $50 \mu\text{mol quanta m}^{-2} \text{s}^{-1}$). While the Light Curve is being recorded, the user can either follow the development of the ETR parameter by checking the ETR box or the development of several quenching parameters by checking the Fluorescence box and selecting/checking the parameters of interest in the **Light Curve window**. The Light Curve starts with an F_0 , F_m -determination. If there is still an active F_0 , F_m determination the software will ask the user, on starting the Light Curve protocol, if this determination should be kept. If the user clicks “no”, the Light Curve starts with a new F_0 , F_m determination. This is, however, formally only correct if the sample is in the dark-acclimated state. If a Light Curve is recorded following an Induction Curve the previous F_0 , F_m determination should be retained (provided the position of the sample was not changed).

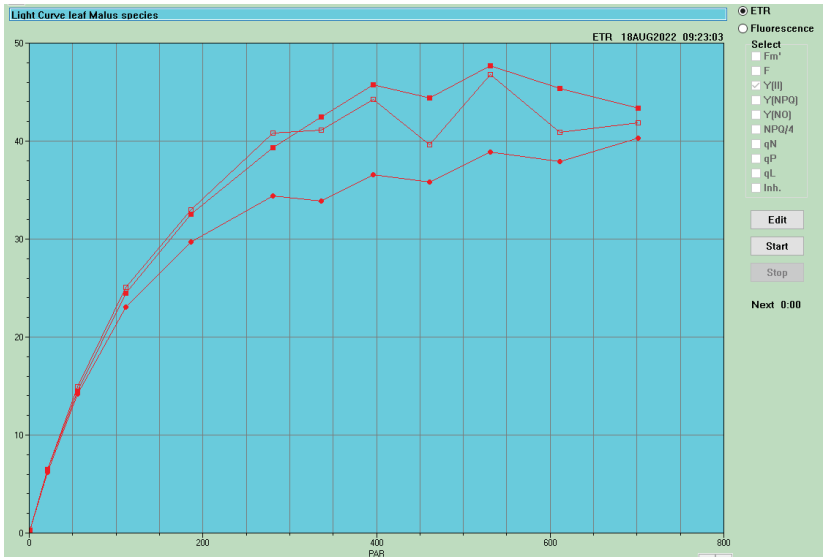

Fig. 18: Light Curve tab showing Light Curves for three AOIs on a *Malus* leaf, for which the averaged values of the ETR parameter (relative apparent electron transport rate) is displayed.

The graph in the ImagingWin Light Curve tab shows light curves for three AOIs of a *Malus* leaf Fig. 18, for which the averaged values of the ETR parameter (relative apparent electron transport rate) are displayed.

ETR is a relative measure of the apparent electron transport rate. It initially shows an almost constant slope and saturates at high light intensities, in analogy to conventional light response (PI) curves. It has to be kept in mind, however, that PI-curves are measured with much longer acclimation times at each light intensity step.

The original definition of the ETR-parameter is based on a uniform absorption of incident light over the whole sample area:

$$ETR = Y(II) * PAR * 0.5 * Absorption$$

The Absorptivity parameter describes the fraction of incident light which is absorbed. The factor 0.5 implies that only half of the absorbed quanta is absorbed by PS II (under steady state conditions). In most studies carried out with standard PAM fluorometers, like the PAM-2500 or MINI-PAM-II, it is assumed that Absorptivity (the fraction absorbed light) equates 0.84, which is the mean value determined for a large number of healthy green leaves of vascular plants with the help of an Ulbricht Sphere.

As all imaged parameters have to be normalized to values between 0 and 1 (for the sake of a uniform false color scale), the calculated PS-values are divided by the expected maximal rate, the preset value of which is 50.

The PS/50 image may reveal that a homogeneously green looking leaf may show distinct heterogeneities in photosynthesis.

These first measurements on one hand demonstrate the simplicity of measurements with the IMAGING-PAM and on the other hand give a first impression of the vast potential of this tool for the assessment of photosynthetic parameters. This introduction should enable the user to get acquainted with the instrument and to start carrying out his or her own experiments. For quantitative work more information may be required. In section 4 the numerous functions and features of the ImagingWin software are described systematically and in more detail. Unavoidably, there will be some overlap with the information given in chapter 3.6.3.

4 ImagingWin

Except for the POWER ON/OFF switches (see 3.6.3) on the front panel of the POWER-SUPPLY, the IMAG-HEX is fully operated via the PC using the ImagingWinGigE software.

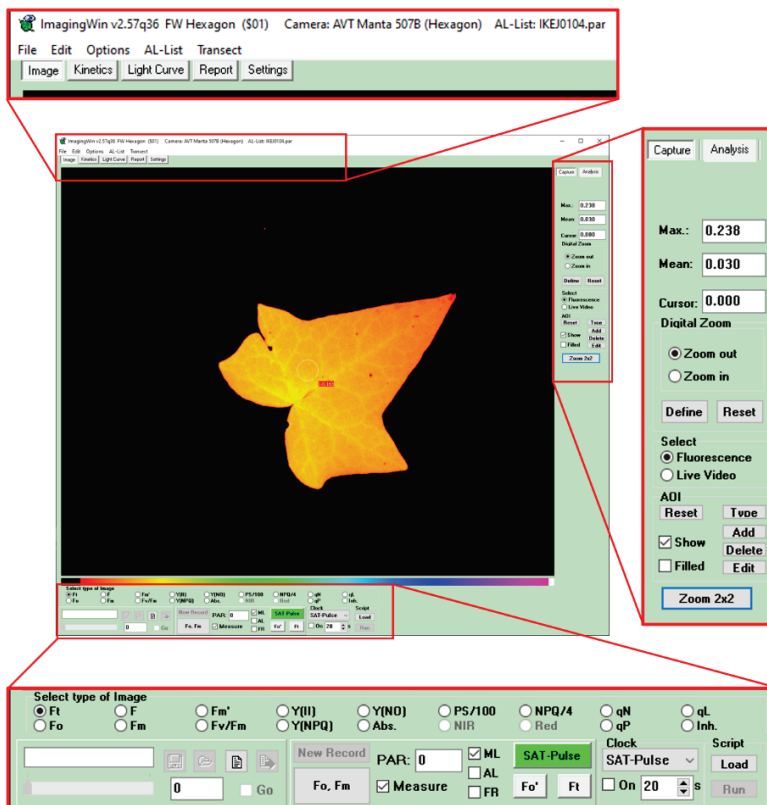

Fig. 19 User interface of ImagingWinGigE after start of the program (the image window with the parameter selection bar is disengaged when a tab like Kinetics, Light Curve or similar is selected in the main window. In the figure some areas with essential control elements are shown enlarged.

The image above (Fig. 19) shows the user interface of ImagingWinGigE after starting the program, as seen on the PC monitor screen. For better orientation, in many places in this manual the overall window is shown quite small, together with an enlargement of the area of interest.

The screen is divided into three sections. The uppermost section, containing the menu bar (see chapter 7).

A major central part, the nature of which changes with the particular window selected via five buttons: Image, Kinetics, Light Curve, Report, Settings (see section 5).

Finally, a bottom section, where different functions needed for **system operation** (like saving data, starting measurements, on/off of ML and AL, etc.) are found. This section remains unchanged in response to the choice of a different window (chapter 5).

- 1) When the program is started, the image window is displayed by default in the middle part of the screen. The user can switch to another tab by clicking on one of the other four buttons mentioned in the previous section. The different tabs are explained in more detail in the following sections below.
- 2) At the bottom of the main ImagingWin window different types of functional elements, essential for manual operation of the HEXAGON-IMAGING-PAM, are located:

Depending on whether the software is currently in measurement mode or in view mode after a measurement, other functions appear as active. Functions that cannot be accessed in the selected mode are grayed out.



a) View Mode

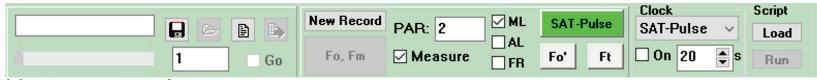

b) Measure Mode

Fig. 20 manual system operation part of the ImagingWin software. Can be found on the bottom of the main window.

- The functional elements on the left side are related to the



recorded data
(viewing, saving, opening and export of data).

The availability of the functions depends on the mode in which the software is running (here the **View Mode** layout is shown).

- The 'left' center area contains the function elements needed to define a new record (**New Record, Fo, Fm**

determination). Both buttons are only available when the software is in the measure mode.



- The functional elements located in the ‘right’ middle section are related to the **different types of light sources** (PAR,

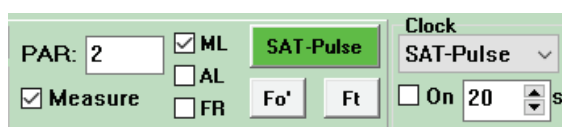

ML, AL, Ext, SAT-Pulse, AL+Y,

Clock). In the check boxes it can be seen if the measuring light, the actinic illumination, or the far-red light sources are currently switched on. The value next to PAR indicates the current light intensity applied (please note that the shown value is taken from the used **light list** and or represents the

real-time PAR value coming from the universal light meter ULM-500.

- The remaining elements on the extreme right-hand side are needed for the automated operation of a HEXAGON- IMAGING-PAM using **script files** (Load, Run).

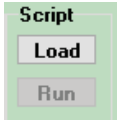

- 3) In the menu bar at the top of the screen the dropdown menus of File, Edit, Options, AL-List, Recalc and Transect are found.

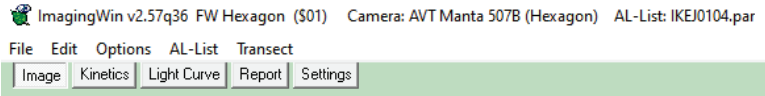

In the status line of the ImagingWin main window information like software version number, PAM model, connected camera model and the loaded PAR list can also be found.

With the help of the tabs below preprogrammed runs, the data table and Settings can be assessed.

Further details on the mentioned software user interface can be found in the following chapter.

5 IMAGINGWIN - System Operation

5.1 Definition of New Record

5.1.1 Fo, Fm

When ImagingWin software is started, it is already in the measure mode and a “New Record” is active. For this reason, the button New Record is inactive. It will be activated after the first measurement (storage of an Ft value or application of a Saturation pulse).



The Fo, Fm-determination is of central importance for the recording of images with the HEXAGON-IMAGING-PAM. Only after the appropriate determination of Fo and Fm with a more or less dark-acclimated sample, the subsequently measured values of the fluorescence parameters qP, qN and NPQ will be meaningful.

All data recorded after an Fo, Fm-determination are stored as one “Record” in a buffer memory (see below) and later may be saved as a PAM Image (PIM) file. Only one Fo value and a single Fm value can be stored within a record.

Please note that together with the Fo, Fm-determination all data that are at that moment stored in the buffer memory are erased.

Therefore, the software asks: “**Save previous Record?**” If this question is answered with “No”, the previously recorded data are irrevocably lost.

Starting a Kinetics recording (see section 5.2) or Light Curve recording (see section 5.3) the software asks: “**Do you want to**

keep the previously recorded Fo, Fm?” While running a Record no Fo, Fm-determination is possible.

Fo- and Fm-images, which can be selected in the Image-window, are prerequisite for the calculation Fv/Fm images and for the calculation of the quenching coefficients qP, qN and NPQ (also for the option “mean over AOI” the measurement of the Fo, Fm is important. See section 7.2.3 on page 115 for more details).

The Fv/Fm image not only defines the maximal PS II quantum yield but is also needed for the definition of the sample limits. This definition is applied to noise suppression outside the sample limits in Y(II) images.

5.1.2 New Record



When starting a New Record, previously recorded data stored in the buffer memory are erased to make room for new data. Therefore, the user is asked: **“Save previous Record?”** If this question is answered with “No”, the previously recorded data are irrevocably lost. Although a New Record is normally started with an Fo, Fm-determination, it is also possible to keep the previously determined Fo, Fm-values (see above section 5.1.1).

It is also possible to carry out measurements applying Saturation Pulses without a previous Fo, Fm-determination. In this case, however, no quenching coefficients that depend on Fo or Fm can be calculated and also the noise suppression based on the Fv/Fm image (see above) or the option “Mean Over AOI does not work (see section 7.2.3 page 115). A later Fo, Fm-determination made while data are being recorded is not possible. As soon as a new Fo, Fm-determination is carried out, a Record is started.

The start of an **Induction Curve** (under Kinetics, see section 5.2) or a **Light Curve** (see section 5.3) is equivalent to the start of a New Record. Previously defined areas of interest (AOIs, see section 6.1.2.1) are not erased when a **New Record** is started, such that several Records (e.g., Light Curves and Induction Curves) can be measured for the same AOIs. AOIs can be reset and newly defined at any time in the View Mode, but it should be avoided to place new AOIs during a measurement. Wait until the experiment has ended to add new AOIs.

5.1.3 Measure



Measure

With the help of the Measure checkbox, it is possible to switch between **Measure mode** and **View mode** and vice versa.

In Measure mode only the images recorded during the last measurement (last Saturation Pulse) are displayed in the image window, whereas in **View mode** all previously recorded data of a record can be viewed in the image window.

In View mode the functions located in the box at the left side apply (viewing, saving, opening and export of data). Although measurements (i.e., recoding of data) are only done in Measure mode, the different types of illumination (AL, ML) are not affected by switching to View mode. In this way, it is possible to keep a sample in a defined light state, while viewing previously recorded data.

If the user wants to stop illumination, the different types of illumination (ML, AL and Clock) have to be switched off manually. The **Save**-icon (see section 5.2) is also accessible in Measure mode. When it is clicked, Measure mode is temporarily quit, and the software switches to View mode (see section 5.2) to allow to save the data. Once the data are secured, the program

switches automatically back to Measure mode, and the recording of data in the active Record can be resumed.

5.2 Functions applying to View mode

The software switches automatically to **View mode** after unchecking the **Measure checkbox** (section 5.1).

Data previously stored in the **Buffer-Memory** can be viewed in the Image-, Kinetics-, Light Curve- and Report-windows. In View mode new Areas of Interest (AOIs) can be defined and old AOIs can be edited or erased.

For the analysis of the data at least one AOI has to remain or to be defined new.

Note, however, that Ft data can only be recorded for AOIs that were defined before the experiment. AOIs that are edited or repositioned during or after an experiment will not carry Ft information that can be stored. Ft data is also removed from a dataset when an AOI is deleted.

To measure a Kinetic or Light Curve, at least one Area of Interest (AOI) has to be defined (see section 6.1.2.1).

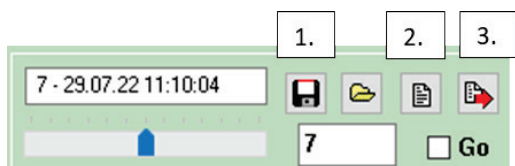



Fig. 21 Buttons related to the View mode: Scroll slider, save, open file, open comment, export.

In the upper section line of the next figure, measuring point number (number of the recorded Saturation Pulse

within a Record) with its date and the time step is shown above. Using the mouse, the **slider** in the lower display line can be moved

left or right, allowing the manual selection of the image associated with a particular saturating pulse during a measuring sequence.

In the field on the right side of the main window (Fig. 19 page 33) gives the number of the currently selected image/Saturation Pulse (here: #7, also active in Measure mode, counting up during the experiment).

 **Go** When the Go box is checked, the images stored in the Buffer-Memory are automatically displayed sequentially at a rate determined by the parameter **Go Speed** (can be modified in the Settings window, section 6.5.7 page 98). After displaying the last image, *Go* automatically continues with the first measurement and resumes as loop.

Please note that the **Yield-filter** (see section 6.5.10 page 99) slows down the image build-up of all calculated parameters and, therefore, should be switched off when high Go Speeds are selected.

 **Save (1)** The data transiently stored in the Buffer-Memory can be permanently saved on the hard disk in the form of a **PAM Image (xpim)** file by clicking the “diskette” icon. Data can also be saved in Measure mode while recording data (see section 5.1.3). Data are saved in the Data_Hexagon directory. Together with the Data file, a comment (*.txt) file containing a description of or notes related to the experiment can be created and saved (see Open comment window).

 **Open data file** PAM Image files stored on the hard disk can be opened by clicking the “folder”

icon and selecting a file. The data contained in this file are subsequently loaded into the Buffer-Memory. Then, if desired, new AOIs can be defined.



Open comment window (2) Clicking on this icon opens the comment window mentioned in the previous item, associated with the current PAM Image (xpim) file. The first time the user clicks on this icon the field is still empty.



Export (3) Data stored in the Buffer-Memory can be exported in the form of **JPEG-** or as (stacked) **TIFF-files**. A JPEG-file contains one particular exported image, which at the moment of export was shown in the Image window. It is relatively small (ca. 100 KB). On the other hand, TIFF-files are rather large (ca. 70 MB for a 13 Saturation Pulse Light Curve). They contain in essence the same graphical information as the original *.xpim files. Each TIFF file consists of a series of images of the following parameters: Fo, Fm, empty, Red, F1, Fm'1, F2, Fm'2, F3, Fm'3 etc. On the basis of these images, images of all other fluorescence parameters can be derived (for formulas see section 6.1.1 page 47). TIFF-images are monochrome without false color coding. These images can be evaluated by image analysis programs like the free ImageJ software.

5.3 Light controls

The HEXAGON-IMAGING-PAM uses the same LEDs for pulse-modulated Measuring Light (ML), Actinic Light (AL) and Saturation Pulses.

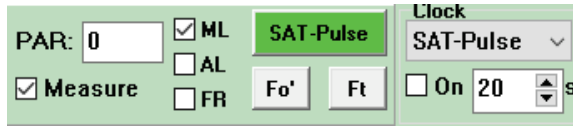

Fig. 22 Manual light controls, trigger buttons and user information in the lower left section of the ImagingWin main window (Fig. 19 page 33)

ML By checking/unchecking the ML box, the user can toggle between **Measuring Light on/off**. The ML frequency and intensity can be changed in the Settings window section 6.5.1 page 88.

AL By checking/unchecking the AL box, the user can turn the **Actinic Light** on/off. If AL is set to 0 (Settings tab section 6.5.1 page 88, actinic illumination continues till it is manually turned off). If an AL time is defined in the Settings window AL will be switched off automatically when the set time is finished. When AL is switched on, the ML frequency automatically is switched to the maximum setting 8.

FR By checking/unchecking the FR box, the user can turn the far-red light source on/off. The FR intensity can be changed in the Settings window described in section 6.5.1 page 88.

PAR Box displaying the light intensity (**Photosynthetically Active Radiation**) of the incident light on the sample plane in $\mu\text{mol quanta m}^{-2}\text{s}^{-1}$ corresponding to the Actinic

Light intensity and as well as (although to a much lesser extent) to the effective Measuring Light intensity (which depends on both the intensity and frequency of the ML pulses). These intensities are given by the intrinsic **PAR-Lists** (see Options menu section 7.3 page 120).

The PAR values were determined at a fixed distance between LEDs and sample plane with the help of a micro quantum PAR sensor. For each measurement (defined by a Saturation Pulse) the momentary PAR-value is stored in the report. It is also displayed in View mode in a PAR display of the main software window Fig. 20. The PAR-values for the 20 AL-intensity settings, as well as for ML-frequency 8 (equivalent to AL 0), are stored as default.par file in the Data folder of the HEXAGON-IMAGING-PAM. It can be viewed and/or modified under AL-List (LED currents/PAR values see section 7.3).

SAT-Pulse key to manually trigger a single **Saturation Pulse**. It represents a measurement (i.e., determination of F and Fm' and real-time calculation of the derived fluorescence parameters), with the obtained data stored in the buffer memory. In the **Settings** tab you can set the set values for SAT pulses (duration and intensity).

AL + Y Button to trigger a period of **actinic illumination** followed by a **Saturation Pulse** (the length of which is defined in the Settings window: Act. Light Width). The AL + Y function is not available when Act. Light Width is set to zero (meaning that AL stays on until it is switches off by the user).

Clock

When the Clock checkbox is checked, the selected Clock command is repeated at a rate defined by the set time interval until the box is manually unchecked again. The Clock interval can be set between 5 s and 3600 s (1 hour). The user can choose between four different Clock commands: SAT. Pulse, AL, AL + Y and Ft only. Whereas the “SAT. Pulse” and “AL + Y” Clock commands involve the repetitive application of Saturation Pulses and, hence, correspond to the measurement of fluorescence parameters, this is not the case for the “AL” Clock command it just switches the actinic illumination on and off according to the intensity settings made in the Settings tab. A particular case is the “Ft only” Clock command, which allows repetitive measurement of Ft without application of a Saturation Pulse. In the absence of actinic illumination, this allows the user to follow changes in Fo or Fo'-images. In the case of the “AL” and “AL + Y” Clock commands, the user should check that the Clock interval is longer than the Act. Light Width.

6 IMAGINGWIN - Tabs

6.1 Image-window

The major part of the Image-window is occupied by the actual Image, at the bottom of which the **false color code bar** is shown. The standard false color code ranges from black via red, orange, yellow, green, blue and violet to purple. These colors code for **numbers between 0 and 1**.

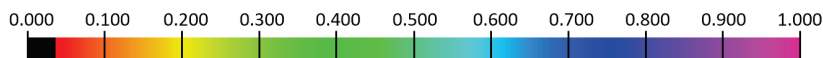

Hence, all measured or calculated parameters are normalized to values between 0 and 1. The correspondence between color and numerical value can be evaluated with the help of a “**Ruler**”, which can be installed above the false color bar via **Options** in the menu (section 7.2 page 114). Instead of a false color bar also the corresponding black-and-white bar (**grey scale**) can be shown (via the B/W check box in the Settings window, section: Display 6.5.6 page 96).

In the middle of the Image, by default, an **area of interest (AOI)** is defined in the form of a circular AOI which is accompanied by a little red box displaying the average value of the selected fluorescence parameter of the area covered by the AOI (see also section 6.1.2.1 page 60).

Below the Image-area the various parameters are listed, images of which can be selected by clicking the corresponding radio buttons (**Select type of Image**) (see section 6.1.1). On the right-hand side of the Image-area a number of functional elements are located which are used for **image capture and analysis** (see section 6.1.2).

6.1.1 Different types of images



Under **Select type of Image** one out of 16 different parameters can be selected, the image of which is then displayed in the Image-window. The meaning of the various parameters will be briefly described in the following subsections. The **Image Window** is mostly disengaged to the left from the main window so that the user can follow the result directly in the image while setting parameters.

6.1.1.1 Current fluorescence yield, Ft

The current fluorescence yield, Ft, is continuously monitored in Measure mode (see chapter 5 page 37), when the Measuring Light (ML) is switched on. Images of Ft are only transiently stored in the Buffer-Memory. However, the current Ft image can be stored at any time by applying a Saturation Pulse. Then the current Ft-image is stored in form of an F- or Fo-image. The latter applies, if the Saturation Pulse is given in the form of an Fo, Fm-determination (see chapter 5.1.1). It is also possible to measure Ft-images without application of a Saturation Pulse with the help of the “Ft only” Clock command (see section 5.3).

Kinetic changes in Ft can be recorded in the Kinetics-window in combination with measurements of dark-to-light induction curves or light response curves for selected areas of interest (AOIs). In this case, Ft-values are stored continuously, i.e., also between saturating flashes.

6.1.1.2 Dark fluorescence yield, Fo

The dark fluorescence yield, Fo, can be assessed after dark acclimation using the Fo, Fm-button. After dark acclimation normally all PS II reaction centers are open and maximum photochemical quenching is observed. This does not necessarily mean that Fo is the minimum fluorescence yield. The fluorescence yield can drop below the Fo-level by strong non-photochemical quenching induced during illumination. When an Fo measurement is triggered, the current Ft is averaged for 3 s and the averaged value is denoted Fo. An Fo determination is essential for the correct calculation of the quenching coefficient qP (see section 6.1.1.13).

6.1.1.3 Fluorescence yield, F

As with all fluorescence parameters (except Ft), fluorescence yield, F, is assessed when a Saturation Pulse is triggered. The current Ft is then averaged over 3 seconds and the averaged value is designated F. As with all fluorescence parameters measured in response to a saturation pulse, F images are stored in the buffer memory.

6.1.1.4 Maximal fluorescence yield, Fm

Maximum fluorescence yield (Fm) can be assessed after dark adaptation using the Fo, Fm key. The Fm value is assessed at the plateau level reached during the application of a saturation pulse. During the saturation pulse, the measuring light frequency is automatically switched to the maximum setting. Fm is evaluated by averaging 3 images.

After dark acclimation the extent of energy dependent non-photochemical quenching is normally minimal. An Fo, Fm determination at the start of a New Record (see chapter 5.1.2 page

34) is essential for the correct calculation of the quenching parameters qP , qN and NPQ . The F_m image measured at the start of a record remains unchanged until a new record is started by a new F_o , F_m determination. In this respect, F_m (a reference value) is different from F_m' , whose images change with each saturation pulse (see below).

6.1.1.5 Maximum fluorescence yield, F_m'

In illuminated samples, a maximum fluorescence yield (called F_m') is observed, which is normally lower than the F_m of the dark acclimated sample, due to its non-photochemical quenching. The value is assessed at the fluorescence plateau level reached during application of a Saturation Pulse. During the Saturation Pulse the Measuring Light frequency is automatically switched to the maximum measuring frequency of 8 Hz.

A given sample can yield an infinity of different F_m' -images, depending on the illumination state at the moment of the application of the Saturation Pulse. On the other hand, the same sample is characterized by unique F_o - and F_m -images, which are determined with a dark-acclimated sample (see sections 6.1.1.4 and 6.1.1.2).

6.1.1.6 Maximum PS II quantum yield, F_v/F_m

The maximum PS II quantum yield, F_v/F_m , is determined after dark acclimation. It is calculated according to the equation:

$$\frac{F_v}{F_m} = \frac{F_m - F_o}{F_m}$$

After dark acclimation, normally all available PS II reaction centers are open ($F = F_o$), non-photochemical energy dissipation is minimal ($qN = NPQ = 0$) and the maximum fluorescence yield,

F_m , is recorded when a Saturation Pulse is applied. In this state the fluorescence increase induced by a Saturation Pulse (variable fluorescence, F_v) as well as the PS II quantum yield ($\Delta F/F_m = F_v/F_m$) are maximal. The F_v/F_m image is derived from an **Fo, Fm-determination**. It remains unchanged until the next F_o, F_m -determination. In this respect, the F_v/F_m image differs from the Y(II) image which changes with every Saturation Pulse (see below).

The contrast between the photosynthetically active object and the background matrix is enhanced, by the following logical argument: if $F_m < 0.048$ then $F_v/F_m = 0$. All pixels with values below this limit are displayed in black. In this way, unavoidable noise associated with the F_m -determination can be suppressed. The resulting “**noise mask**” is saved for a given Record and also applied to Y(II), Y(NPQ) and Y(NO) images. Please note that this approach requires that the sample does not move during the recording of a given Record. If sample movement cannot be avoided, quenching analysis is not possible and measurements should be carried out without F_o, F_m -determination.

6.1.1.7 Effective PS II quantum Yield, Y(II)

The effective PS II quantum yield is calculated according to Genty et al. (1989) by the formula:

$$Y(II) = \frac{Fm' - F}{Fm'}$$

As this fluorescence parameter is derived from a ratio of fluorescence intensities, any inhomogeneities of fluorescence excitation intensity or chlorophyll concentration will disappear and any remaining inhomogeneities can be interpreted in terms of differences in activity.

A given sample can yield an infinity of different $Y(II)$ -images, depending on the state of the sample at the moment of the application of the Saturation Pulse. A unique state is obtained after dark acclimation when the effective PS II quantum yield reaches its maximum value (see section 6.1.1.6).

$Y(II)$ measurements normally are preceded by an F_o , F_m -measurement. In this case the contrast between the photosynthetically active object and the background matrix is enhanced, by the logical argument: if $F_m < 0.048$ then $F_v/F_m = 0$. All pixels with values below this limit, are displayed in black in the F_v/F_m as well as in $Y(II)$ images (“noise mask”, see section 6.1.1.6).

By definition, the quantum yield can vary between 0 and 1. For example, if $Y(II) = 0.5$, half of the absorbed quanta are converted into chemical energy by photochemical charge separation in the PS II reaction centers. The other half of the quanta are lost as heat and fluorescence. The sum of all quantum yields always equals 1. Based on the work of Kramer et al. (Photosynthesis Research 79 (2004) 209-218), two other types of quantum yield can be defined, $Y(NPQ)$ and $Y(NO)$, which represent the non-regulated and regulated energy dissipation at the PS II centers, respectively (see sections 6.1.1.8 and 6.1.1.9), and which, together with the photochemical quantum yield, add up to unity.:

$$Y(II) + Y(NPQ) + Y(NO) = 1$$

6.1.1.8 Quantum yield of regulated energy dissipation, $Y(NPQ)$

The quantum yield of regulated energy dissipation in PS II, $Y(NPQ)$ can be calculated according to Kramer et al. (2004) using the equation:

$$Y(NPQ) = 1 - Y(II) - \frac{1}{NPQ + 1 + qL \left(\frac{F_m}{F_o} - 1 \right)}$$

For this equation to be valid, it is essential that the PS II pigments of the investigated sample are organized according to the “Lake model” (Stern-Volmer approach), which may be assumed for most higher plant leaves. The NPQ parameter is a measure for non-photochemical fluorescence quenching (see section 6.1.1.11), reflecting an enhanced dissipation of excitation energy as heat in the PS II antenna, as a protective mechanism against excess light intensities. The qL parameter is a measure for the fraction of open PSII centers in the “Lake model”, i.e., unlimited connectivity between PS II antennae (see section 6.1.1.14).

A high $Y(NPQ)$ value on the one hand indicates that the absorbed photon flux density is excessive and on the other hand shows that the sample still has the physiological means to protect itself by regulation, i.e., the dissipation of excessive excitation energy into harmless heat. Without this type of regulated dissipation mechanisms, the probability that singlet oxygen is formed is considerably higher, which may cause irreversible damage.

In $Y(NPQ)$ images all pixels are set to 0 (black) for which $F_v/F_m = 0$ (“noise mask”, see section 6.1.1.6).

6.1.1.9 Quantum yield of non-regulated energy dissipation, Y(NO)

The quantum yield of non-regulated energy dissipation in PS II, Y(NO), can be calculated according to Kramer et al. (2004) using the equation:

$$Y(NO) = \frac{1}{NPQ + 1 + qL \left(\frac{Fm}{Fo} - 1 \right)}$$

For this equation to be valid, the PS II pigments of the investigated sample must be organized according to the “lake model” (Stern-Volmer approach), which may be assumed for most higher plant leaves. The NPQ parameter is a measure for non-photochemical fluorescence quenching (see section 6.1.1.11), reflecting an enhanced dissipation of excitation energy as heat as a protective mechanism against an excess absorbed light quanta. The qL parameter is a measure for the fraction of open PS II centers derived on the basis of the “lake model”, i.e. unlimited connectivity between the PS II antennae affecting the fluorescence all Ft between Fo and Fm (see section 6.1.1.14).

A high Y(NO) value indicates that both photochemical energy conversion and protective regulatory mechanisms are inefficient. Therefore, it is indicative of plants having serious problems to cope with the incident radiation. Either the photosynthetic apparatus is already damaged, or it will be photodamaged upon further irradiation. Extremely high values of Y(NO) can, e.g., be induced by PS II herbicides, which not only block PS II reaction centers, but also prevent the buildup of a trans-thylakoid proton difference. The latter is an important prerequisite for energy-dependent non-photochemical quenching.

In Y(NO) images all pixels are set to 1 (purple) for which Fv/Fm=0 (“noise mask”, see section 5.4.1.6).

6.1.1.10 Apparent rate of photosynthesis, PS/50

The apparent rate of photosynthesis (PS) can be calculated on the basis of the measured effective PS II quantum yield, the incident photon flux density (PAR) and the PAR-Absorptivity (Abs.):

$$PS = 0.5 * Y(II) * PAR * Abs. [\mu\text{equivalents m}^{-2} \text{ s}^{-1}]$$

The incident PAR is determined for the defined distance between LED-Ring-Array and sample plane (20 cm for the HEXAGON-IMAGING-PAM). It is assumed that 50% of the absorbed PAR is distributed to PS II. As the PS calculated in this way can reach values of around 50, the parameter PS/50 is displayed to depict the apparent rate of photosynthesis with the help of the false color code reflecting values between 0 and 1.

The PS/50-parameter measured with the HEXAGON-IMAGING-PAM corresponds in most respects closely to the ETR-parameter, which was defined in the past for measurements of the apparent rate of photosynthetic electron transport:

$$ETR = 0.5 * Y(II) * PAR * 0,84 [\mu\text{equivalents m}^{-2} \text{ s}^{-1}]$$

This commonly used definition assumes a PAR-Absorptivity of 0.84, i.e., that 84 % of the incident photons of photosynthetically active radiation is absorbed by the leaf. This value can be considered typical for a “standard green leaf”. In reality, however, PAR-Absorptivity may vary considerably, e.g., between the upper and lower leaf side, as well as between different species and leaves in different developmental stages. The latter is particularly evident during senescence. Even a single leaf may show considerable lateral heterogeneity of PAR-Absorptivity, in particular, these can be caused by virus infections and other plant diseases that disturb pigment synthesis.

6.1.1.11 Nonphotochemical quenching, NPQ/4

The NPQ parameter provides a measure for non-photochemical quenching, which in contrast to qN does not require knowledge of Fo' (see section 6.1.1.2). It is defined according to the equation:

$$NPQ = \frac{Fm - Fm'}{Fm'} = \frac{Fm}{Fm'} - 1$$

In contrast to the quenching coefficient qN , the parameter NPQ can reach values higher than 1. In practice, NPQ rarely exceeds 4. Hence, images of NPQ/4 are created, yielding values ranging between 0 and 1, that can be displayed using the standard false color code.

The definition of NPQ implies a matrix model of the antenna pigments (Stern-Volmer quenching). NPQ reflects regulated non-photochemical quenching due to enhanced/upregulated heat-dissipation of excitation energy in the PS II antennae. NPQ has been shown to be a good indicator for “excess light energy”, which in leaves is primarily dissipated via zeaxanthin (xanthophyll cycle) in the presence of a trans thylakoid ΔpH .

Assessment of NPQ requires a preceding determination of Fm with the same sample after dark acclimation, i.e., under conditions when, by definition, $NPQ = 0$.

6.1.1.12 Coefficient of nonphotochemical quenching, qN

The coefficient of non-photochemical quenching, qN , is defined by the equation:

$$qN = 1 - \frac{Fm' - Fo'}{Fm - Fo} = 1 - \frac{Fv'}{Fv}$$

qN can vary between 0 (defined for the dark-adapted state) to 1 (all variable fluorescence quenched). In most cases qN does not only reflect the non-photochemical quenching of variable fluorescence (induced upon reaction center closure), but also of the dark-level fluorescence (all centers open). Increased qN is primarily due to increased heat dissipation induced during illumination. For correct determination of Fo', it would be necessary to switch off the actinic light and to quickly re-oxidize the PS II acceptor side with the help of far-red light before non-photochemical quenching can relax. Alternatively, Fo' can be estimated using the approximation of Oxborough and Baker (1997):

$$Fo' = \frac{Fo}{\frac{Fv}{Fm} + \frac{Fo}{Fm'}}$$

This approximation relies on the assumption that the same mechanism that causes quenching of Fm' with respect to Fm is also responsible for Fo-quenching. The quenching coefficient qN is quite sensitive to changes in the energy status of the chloroplasts (energy-dependent quenching). Such changes are readily induced by various environmental stress factors causing stomatal closure, switching from CO₂-dependent to O₂-dependent electron flow and down-regulation of the rate of energy conversion in PS II. Hence, qN is an indicator of stress induced limitations and, actually, has proven to be the most sensitive parameter for early detection of such limitations by fluorescence imaging.

Assessment of qN requires a preceding Fo, Fm-determination on the same sample made following dark acclimation, i.e., when, by definition, qN = 0.

6.1.1.13 Coefficient of photochemical quenching, qP

The coefficient of photochemical quenching, qP , is a measure of the overall “openness” of PS II. Calculation of qP requires knowledge of the fluorescence parameter Fo' (minimal fluorescence yield of the illuminated sample, which is lowered with respect to Fo due to non-photochemical quenching):

$$qP = \frac{Fm' - F}{Fm' - Fo'}$$

A correct Fo' -determination requires application of far-red light. Alternatively, as the same mechanism causing Fo -quenching is also responsible for quenching of Fm' with respect to Fm , it is possible to estimate Fo' from Fm' measurements (Oxborough and Baker 1997):

$$Fo' = \frac{Fo}{\frac{Fv}{Fm} + \frac{Fo}{Fm'}}$$

Assessment of qP requires a preceding Fo , Fm -determination with the same sample after dark acclimation, i.e., when by definition $qP = 1$.

The definition of qP is based on the “puddle model” of PS II. It is widely assumed though that the antenna pigment organization in leaves is more realistically described by the “lake model”. The “puddle model” assumes that there is no connectivity between the antennae of individual PS II reaction centers, and therefore, excitation energy cannot be transferred between the antennae of closed and neighboring open reaction centers. Hence, the fraction of open PS II centers is thought to be overestimated by qP . The fraction of open PS II centers estimated on the basis of the “lake model” is described by the quenching coefficient qL (see below).

6.1.1.14 Coefficient of photochemical quenching, q_L

The coefficient of photochemical quenching, q_L , is a measure of the fraction of open PS II reaction centers, which can vary between 0 and 1. Its definition is based on the “lake model” of PS II antenna pigment organization. Calculation of q_L requires a determination of the fluorescence parameter Fo' (minimal fluorescence yield of illuminated sample, which is lowered with respect to Fo by non-photochemical quenching):

$$q_L = \frac{Fm' - F}{Fm' - Fo'} * \frac{Fo'}{F} = qP * \frac{Fo'}{F}$$

A correct Fo' -determination requires application of far-red light. Alternatively, as the same mechanism causing Fo -quenching is also responsible for quenching of Fm' with respect to Fm , it is possible to estimate Fo' from Fm' measurements (Oxborough and Baker 1997):

$$Fo' = \frac{Fo}{\frac{Fv}{Fm} + \frac{Fo}{Fm'}}$$

Assessment of q_L on the basis of a calculated Fo' requires a preceding Fo , Fm -determination with the same sample after dark acclimation, i.e., when, by definition, $q_L = 1$.

When during illumination non-photochemical quenching is induced, generally $Fo' < F$ and, therefore, also $q_L < qP$. The difference between these two coefficients of photochemical quenching increases with the connectivity between PS II reaction centers.

6.1.1.15 Inhibition, Inh .

The Inhibition (Inh .) parameter describes the **inhibition of the PS II quantum yield, Fv/Fm or $Y(II)$** of an AOI, relative to a

control, reference, AOI, the number of which can be selected under Settings / Inh. Ref. AOI (see section 6.5.9). After start of the program AOI #1 is the control reference for calculation of the Inh. image according to the equation:

$$Inh. = \frac{Y_{control} - Y_{sample}}{Y_{control}}$$

This parameter is particularly important for assessment of phytotoxicity with **multiwell plates**. For this application wells are filled with algae suspensions and the inhibitory effect of phytotoxicant addition relative to a control sample is assessed. In this case AOI #1 is defined for the well of the control sample, which always displays the highest Y(II) value.

Images of Inh. can also be informative in the case of applications with other samples, like leaves. In phytopathological studies, for example, the inhibition of an infected area relative to a control area (defined as AOI #1) can be displayed.

Like all other imaged parameters, the Inh. parameter ranges from 0 (black) to 1 (purple). To assure a good contrast between sample and background, in the case of Inh. images the latter is white instead of the usual black.

6.1.2 Image capture and analysis

The functional elements for image capture and analysis are located at the right-hand side of the Image-window. The standard Image-window is shown when **Capture** is selected. The image of a particular parameter can be modified, emphasizing certain features, when **Analysis** is selected. The various functional elements are described in the following sections.

6.1.2.1 Area of Interest, AOI

The displayed image is composed of 1000 x 1200 (i.e. 1.2 MP) pixels (in 2x2 camera chip binning). Each pixel captures its own fluorescence kinetics, such that in principle 1200000 Light Response Curves are recorded. In practice, however, it is necessary to reduce this vast amount of information.

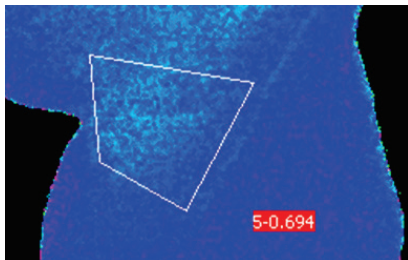

For this purpose, **Areas of Interest (AOIs)** have to be defined. The values of the pixels forming the AOI are averaged, and this average value is shown in a little box adjacent to a particular AOI.

By averaging, the pixel noise is considerably reduced.

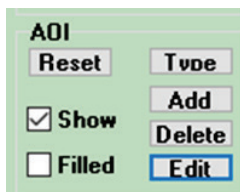

The definition of at least one AOI is required for the recording of Induction Curves (see section 6.2) and Light Curves (see section 6.3). When the program is started one **standard AOI circle** is by default created in the center of the image area. This AOI can be removed clicking the **Reset**-button or moved by clicking the **Edit**-button. Please note that editing an AOI is only possible for the circular shapes. The function is not available for the rectangular-, polygon- or leaf-type AOIs.

New AOIs can be created using the **Add**-button. After clicking “Add”, a standard circle can be moved with the help of the mouse cursor to the desired position. With the help of the **+ keyboard key** the circle diameter can be increased. With the **- key** it can be decreased. The AOI position and size are set by mouse click (left or right). The AOI-size will remain unchanged when further AOIs are added unless it is modified using the +/- keys. The last added

AOI can be removed via **Edit/Undo** (Menu). All AOIs can be removed by **Reset**. A particular AOI can be deleted clicking **Delete**. After clicking the Delete button a **Delete-hand** appears that can be moved to the AOI that has to be deleted using the mouse. Please note that the pointing finger has to be placed inside the AOI. When the **Show**-checkbox is deactivated (unchecked), the AOIs disappear, but can be made visible again at any time by checking the **Show**-checkbox. The status of the **Filled** checkbox determines whether or not the area is filled with the color corresponding to the **average parameter value**. When “Filled” is activated, any heterogeneity or structure within the AOI disappears. Only when “Filled” is inactivated it is possible to see, e.g., that a small AOI is covered by a larger AOI.

With the help of the **Type**-button (see next figure) different AOI types can be selected. Besides a **Circle** also a **Rectangle**, **Polygon** or **Leaf** can be chosen. The minimal AOI size is one pixel for a rectangular AOI and a diameter of 10 pixels for a circular AOI.

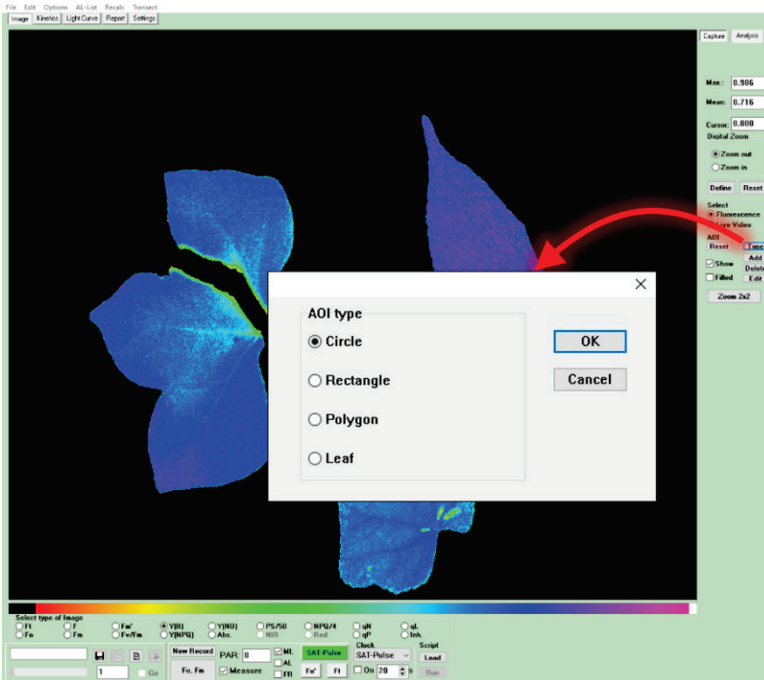

Fig. 23 AOI type selection window. Four different types of AOIs can be chosen here.

To define the size and position of a **Rectangle-type AOI**: after clicking “Add” the mouse cursor is moved to one of the envisioned corners, then the position is fixed by a mouse click (left or right). Then the desired shape and size of the Rectangle can be arranged by moving the mouse. The final state is fixed by another mouse click.

To define the size and position of a **Polygon-type AOI**: after clicking “Add” the mouse is moved to one of the envisioned corners, which is fixed by a mouse click (left or right). Then the mouse cursor is moved to the next corner, which is fixed by mouse click and so on. The last segment is created by a **double-click** on

the last corner, which leads to the creation of the segment connecting the last and the first corner.

Up to 99 AOIs can be defined per record.

The **AOI Type** must be selected before clicking “Add”; after clicking “Add” the Type-selection is no longer accessible.

A special routine is provided for definition of an **AOI-array**, as, e.g., required for assessment of samples in multiwell plates. This routine is accessible under Options/Define AOI array geometry/Create AOI array (see section 7.2).

For several records with samples in always the same pattern.

6.1.2.1.1 Transfer of AOIs between measurements and datasets

For repeated measurements with the same AOI patterns, you can define an AOI layout for the first measurement of the series and perform and save the measurement. Before the next measurement with the same AOI pattern, first call up this previous measurement in View mode (open pim file) and then switch to Measure mode. The AOIs from the previous file are then transferred to the current measurement.

The transfer of AOIs between existing pim files is also possible. It is important to know that old pim files will be saved in the recent xpim format after they have received a new AOI pattern.

To transfer AOIs with the new software to a new dataset, please use the ImagingWin software in "View Mode" (measure box unchecked). If no IMAGING-PAM is connected, view mode is active anyway. Then selects the File that you would like to evaluate with the new AOIs, and press enter. The AOI pattern overwrites the pre-existing AOIs from the receptor file.

In case AOIs still have to be moved (applies only to round AOIs), it is still possible to modify individual AOIs after the transfer using the "edit" function of the ImagingWin software (position, size, delete). Of course, additional AOIs can also be inserted.

The receptor-file must be manually saved for the changes to become valid.

6.1.2.2 Select: Fluorescence or Live Video



When the program is started the measuring system is in **Fluorescence Mode**. This means that the fluorescence yield is assessed by the pulse modulated **blue measuring light**. In this way the momentary Ft image is continuously and transiently captured. A rather low pulse frequency is applied to avoid an actinic effect of the measuring light. Consequently, the time resolution of the image-sequence is low, and it is difficult to follow the moving of the sample or the focusing of the camera lens based on the fluorescence image.

When **Live Video** mode is selected, the blue fluorescence measurement light is switched off and the **NIR measuring light** is switched on instead, which is not visible to the human eye and has no actinic effect on PS II. However, NIR is detected by the CCD camera and can therefore be used to **image the leaf** (monochrome) at a relatively high measurement pulse frequency without being actinic or having a pre-illumination effect on the photosynthetic apparatus. Live video mode is therefore useful for positioning the leaf sample in the field of view and **focusing the image**.



Fig. 24 Selection window for Live Video intensity and color mode – no image saving option.

When Live Video is activated, a separate Live Video window appears where the NIR intensity can be adjusted.

If the Overload box in the Live Video window is ticked, this indicates that the total amount of light seen by the CCD camera is too high and therefore the measured NIR image is likely to be distorted. The total signal consists of the ambient background light (e.g. from daylight) and the reflected NIR light. Therefore, in case of overload, either the incident ambient light intensity should be reduced (recommended) or the NIR intensity should be reduced.

Live video images can also be captured using continuous light from any external light source that can pass through the filters in front of the CCD camera.

To quit Live Video mode and to return to Fluorescence mode click the **Close** button on the right-hand side or the **Exit button** in the upper right corner of the **NIR intensity** adjustment window.

6.1.2.3 Zoom

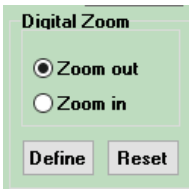

The standard display of images (**Zoom out**) includes all 1000 x 1200 (i.e. 1.2 Mpx) pixels. Without zoom, individual pixels are not visible; they become increasingly visible as the zoom factor is increased. The default zoom factor of 2 is applied when “**Zoom in**” is clicked. A quarter of the total area is then displayed in the center. At this magnification the individual pixels are just visible. The zoom factor can be defined by the user by clicking on the **Define Zoom button**, which is only possible in the Zoom Out position. After clicking on Define Zoom, the cursor must be moved to one of the corners of the desired zoomed image. This corner is fixed with a mouse click (left or right). The desired size of the zoom image can then be adjusted by moving the arrow to the diagonally opposite corner of the desired image rectangle. Click again to fix the final size. To change the zoom factor, always select Zoom out before clicking on Define Zoom again. The **Reset** button resets the system to the standard zoom with zoom factor 2 (display of the central quarter of the image). Once the sample has been zoomed in, AOIs can be added which will follow the changes in scaling when zoomed out.



Below the AOI menu there is another button that allows the Zoom in the image by the factor 2. This 2x2 px binning works on the basis of another principle than the purely graphical zooming discussed above. Binning is the process of combining neighboring picture elements (pixels) on a camera sensor. By forming pixel blocks into virtual pixels, a higher light sensitivity is achieved, and the signal-to-noise ratio is improved because the noise is statistically distributed. In return, however, the image resolution is also reduced according to the number of combined pixels, i.e. the image becomes coarser.

6.1.2.4 Cursor

Max.:	0.979
Mean:	0.698
Cursor:	0.000

The **Cursor box** shows the numerical value of the selected parameter at the cursor position. When the cursor enters an AOI, the cursor box will show the same average value as shown in the box close to the AOI, provided “Filled” is active (see section 6.1.2.1).

The fields above the Cursor box show the parameter values applying to the whole image:

Max.: the highest value of all pixels

Mean: the mean value of all pixels

6.1.2.5 Analysis

The **Analysis function** normally is used together with the **Expanded Color** display (see section 6.5.6 page 96). When **Analysis** instead of **Capture** is selected, the color scale of a displayed image can be modified. Using the **Low** and **High** scroll boxes, the **Low-High limits** of the color scale can be defined. The numbers correspond to the pixel value scale ranging from 0.000 to 1.000. In the image displayed under Analysis, all displayed pixels with values within the Low-High limits have a red color, whereas the rest of the pixels is displayed in black-and-white (standard grey scale). The Low-High limits defined under Analysis are effective for the Expanded Color display under Capture. The closer the low and high limits are with respect to each other, the higher is the color resolution of the scale. In this way, small differences in pixel values can be made visible by enhanced color scaling, thus increasing the contrast.

Using the false color scale, maximal contrast is obtained in the range of very low values (from yellow to red and black).

Therefore, to obtain maximal display contrast of a localized lowering of a fluorescence parameter in a particular region of a leaf, the “normal” range of pixel values should be shifted to yellow while the lowered range of pixel values should be shifted to red-black. This can be achieved by suitable shifting of the Low and High limits under Analysis. Under Settings the **Expanded Color** display has to be selected and the image has to be viewed under **Capture**. An example given in Fig. 25 shows a Y(II)-image with normal Color display of a leaf in which the veins display lowered Yield-values. In Fig. 26 the analysis-image and the settings of the Low-High limits are displayed. Fig. 27 shows the same image with Expanded Color display under Capture.

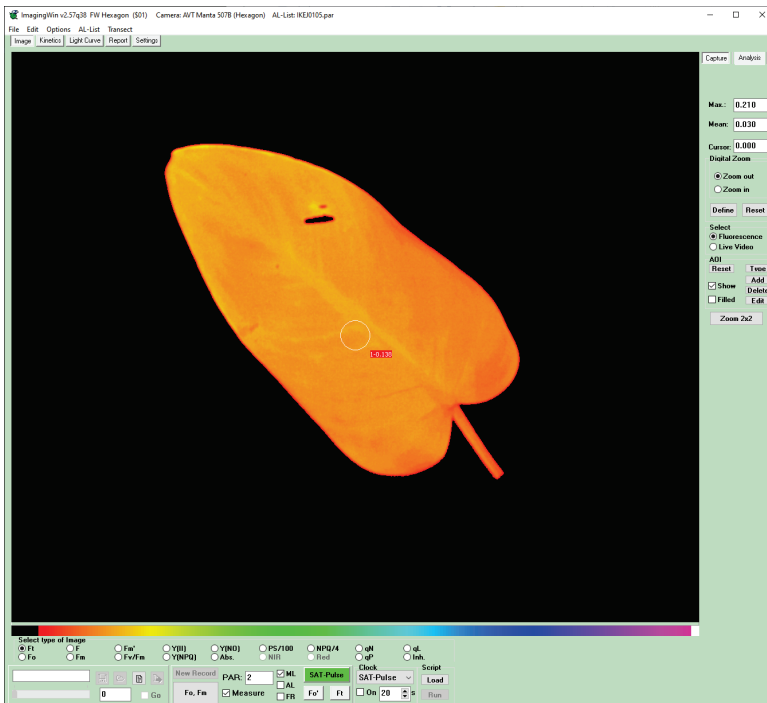

Fig. 25: Normal color display (Ft image in Capture mode)

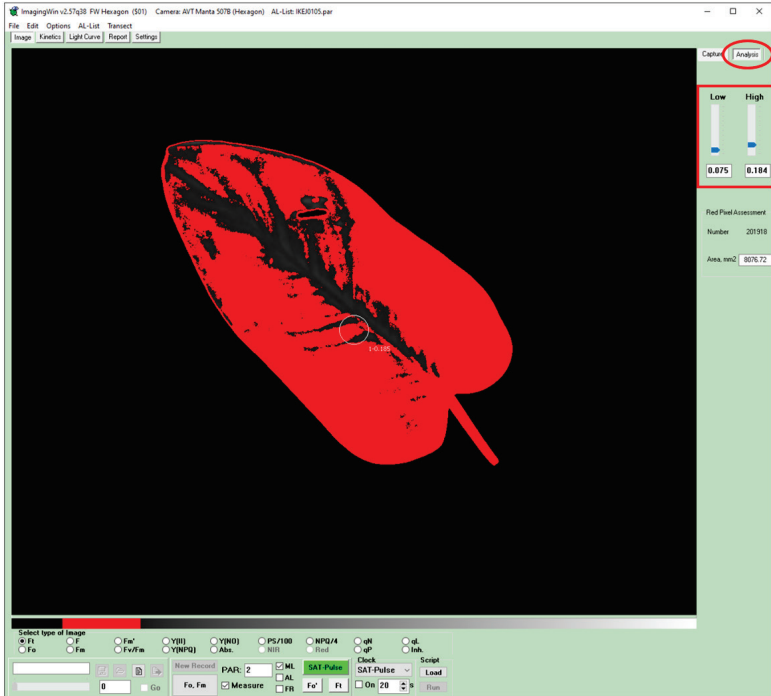

Fig. 26: Display under Analysis with particular settings of Low-High limits (right side marked red)

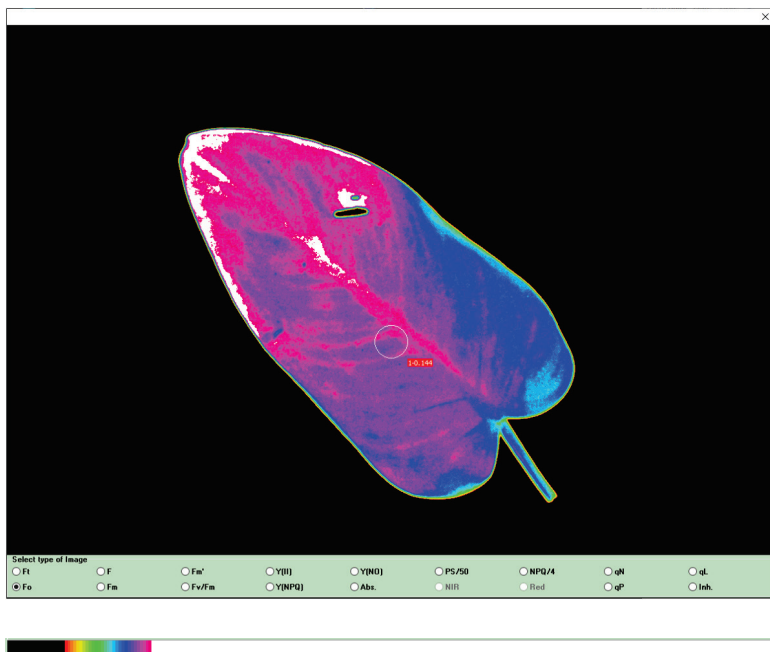

Fig. 27: Expanded Color display with corresponding LUT with limits from the Analysis option (Fo image back in “Capture” in View Mode)

6.2 Kinetics window

In the **Kinetics window** the changes in fluorescence parameters are displayed as a function of time. Following every Fo, Fm-determination, i.e., after the start of each new Record, all measurements are saved in the **Buffer Memory**, as documented in the lower left corner of the ImagingWin user interface (see section 5.2) and in more detail in the **Report file** (see section 5.2 page 40). The same information can be displayed in the form of kinetic curves in the **Kinetics window**. Registration of the kinetic data also occurs in the background, i.e., when the Kinetics window is not active. Data display in the Kinetics window requires that at

least one AOI is selected. If this is not the case, the software gives a warning.

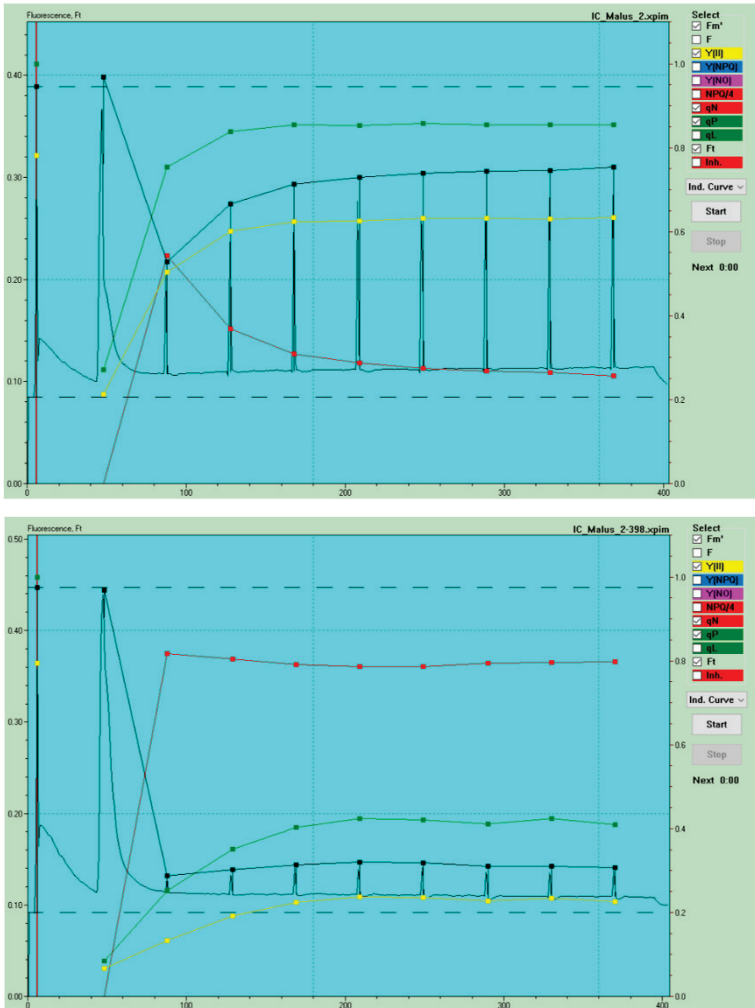
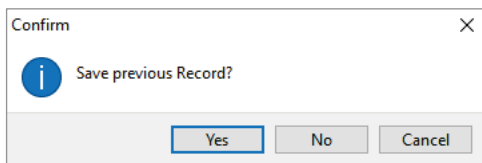

Fig. 28 Kinetics window showing two standard Induction Curves (each with a single AOI) measured with a Malus leaf exposed to respectively 111 (upper) and 398 $\mu\text{mol quanta m}^{-2} \text{s}^{-1}$ (lower curve).

A typical Record of a standard dark-to-light Induction Curve is displayed in

. For the sake of clarity only a selection of the available fluorescence parameters is displayed (F_m' , $Y(II)$, q_N and F_t) and only one AOI is selected. The **Ft-parameter** (momentary fluorescence yield at any time “t”, differs from all other parameters in that it is measured continuously, i.e., not only during Saturation Pulses. However, it should be noted that F_t is recorded exclusively for the **selected AOIs**. Hence, in contrast to all other parameters, it is not possible to display F_t images for AOIs defined after recording of the data (because these data were not stored). Also, in contrast to all other parameters, F_t is not recorded in the background after the start of a New Record (F_o , F_m -determination).



For the sake of a uniform ordinate scale ranging from 0 to 1, F_t is normalized to the F_m -value, i.e., the

ratio F_t/F_m is displayed as a function of time. Hence, before a Kinetics curve can be recorded, F_m must be determined, which is done automatically upon the start of a recording via an F_o , F_m -determination, unless the user wants to keep the previously determined F_o and F_m values. With the definition of F_o and F_m , a new Record is started and the buffer memory with the previously recorded data is erased. Therefore, the user is reminded to save the data before the F_o , F_m -measurement is triggered and is asked if the current F_o , F_m -determination should be kept:

For example, it can be advantageous to keep the previously recorded F_o , F_m , when an Induction Curve is measured after a defined pre-illumination. In this case, F_o , F_m can be measured before the pre-illumination and the F_o , F_m determination preceding the recording of the Induction Curve can be omitted. Then, F_t -normalization as well as calculation of quenching parameters and of F_v/F_m will be based on the F_o and F_m values determined before the pre-illumination.

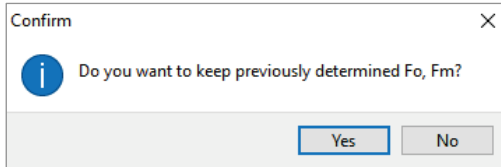

preceding the recording of the Induction Curve can be omitted. Then, F_t -normalization as



the data point **symbols of the selected AOI number** are indicated. Examples are given for 4 out of 7 selected AOIs and 7 out of 7 selected AOIs being active for display, respectively.

The time-dependent changes of **eleven different fluorescence parameters** can be displayed in the Kinetics window by checking the corresponding check boxes. As pointed out above, the F_t parameter

When the **AOI button** is pressed, the AOI window is opened, which shows in its bottom part a list of all AOIs that were defined in the Image-window. By clicking a particular number, the corresponding AOI can be selected for data display in the Kinetics window. However, it is also possible to super-impose the data of several or all AOIs. In the top part of the AOI window,

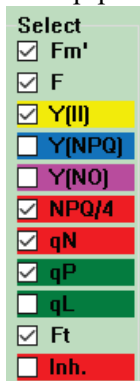

can be displayed only for AOIs which were defined before the start of the Record.

One out of **three different types of Kinetic recordings** can be selected (Manual, Induction Curve, and Induction + Recovery).

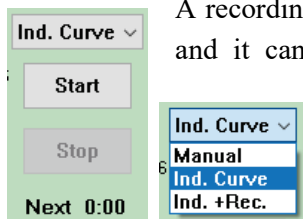

A recording is started by clicking the Start-button and it can be terminated by clicking the **Stop**-button. **Next** refers to the remaining time until the next measurement takes place (i.e., application of the next Saturation Pulse).

Ind. Curve: An Induction Curve is a preprogrammed dark-to-light induction curve (Kautsky effect), the parameters of which can be defined by the user (under **Settings: Meas. Light, Act. Light, Sat. Pulse** and **Slow Induction**). Clicking the Start-button following selection of Ind.Curv., normally the measurement starts with an **Fo, Fm-determination** (unless the user chooses to keep the previously determined Fo and Fm values, see above). Actinic illumination is then started after the chosen **Delay**-time at an intensity defined by **Act. Light Int.** at the chosen **Meas. Light Int.** and the chosen properties of the Saturation Pulses. Saturation Pulses for quenching analysis are given repetitively at user-defined **Clock**-intervals. The length of the recording is defined by the **Duration**-parameter. An Induction Curve is terminated automatically at the end of the preprogrammed Duration-period. It can be terminated earlier with the help of the **Stop**-button, however, not before the end of the Delay-time.

Ind.+Rec.: An Induction Curve + Recovery is a preprogrammed dark-to-light induction curve (Kautsky effect) followed by a light-to-dark fluorescence relaxation curve, which provides information on the **dark-recovery/relaxation** kinetics of fluorescence parameters after a period of illumination; these

parameters are selected by the user. The **Duration**-parameter (defined under Settings: Slow Induction section) defines the period of illumination (as described above for a normal Induction Curve). In the time period following termination of actinic illumination 16 Saturation Pulses are applied with exponentially increasing time intervals between Saturation Pulses [given intervals]. In this way, both the fast and slower recovery kinetics can be recorded and monitored, minimizing the actinic effect of the Saturation Pulses on the slow recovery kinetics. Fig. 29 shows two typical recordings of the Induction Curve + Recovery protocol. In this example the Duration-parameter was set to 400 sec.

Manual: The Manual recording corresponds to a chart recording. When the Ft checkbox is checked, the time courses of the averaged Ft pixel values of all AOIs will be displayed. After clicking the Start-button following selection of Manual, normally the measurement starts with an Fo, Fm-determination. As noted above, the user may also decide to keep the previously determined Fo, Fm-values. It is up to the user when to start the actinic illumination, or when to apply a single Saturation Pulse or repetitive Saturation Pulses using the Clock (in the lower right corner of the screen). A Manual registration is terminated by the **Stop**-button.

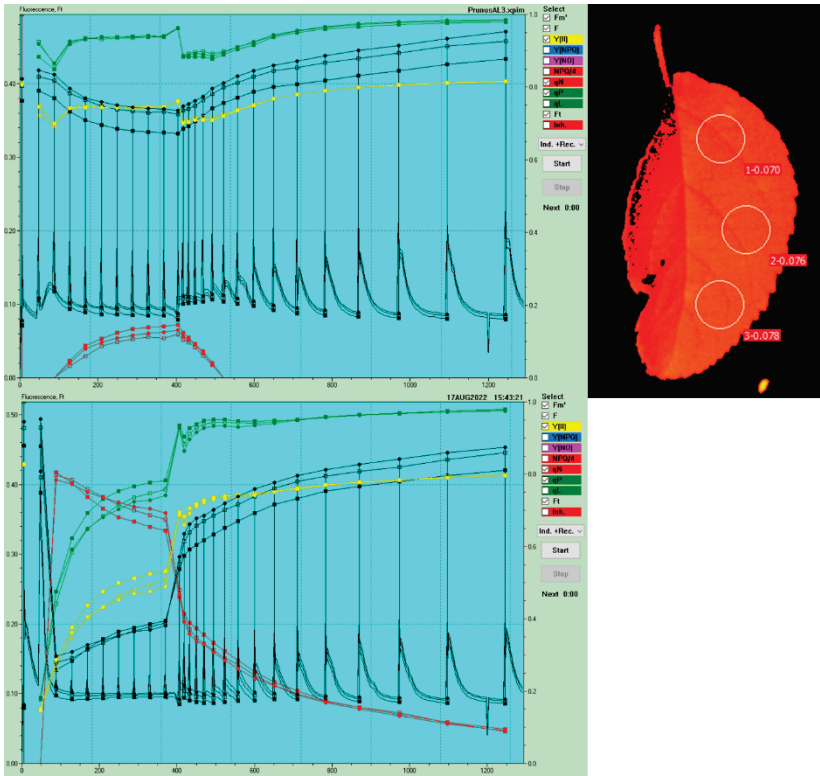

Fig. 29: Typical examples of an Induction Curve + Recovery experiment: top: AL 3, bottom: AL 6, left: position of AOIs on the Malus leaf used for the measurements.



When the **Autoscale** icon is clicked, the scale of the time axis is automatically adjusted to the length of the experiment.

t: F: Y:

The **t-F-Y boxes** show

the coordinates of the cursor position, with t corresponding to the time (sec) and F corresponding to the pixel value of the selected fluorescence parameter, whereas Y corresponds to the Y-coordinate on the screen.

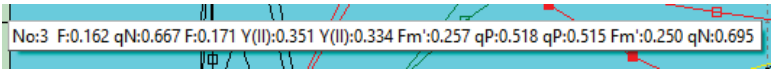

When the **cursor** is placed on a data point for a period of 10 sec the measurement number and the values of the selected parameters are shown.

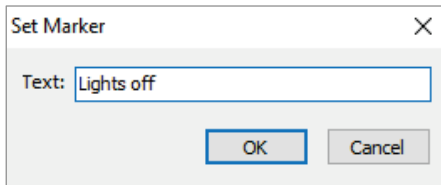

An **event marker** can be set in the form of a **vertical red line** and a corresponding **event text** may be entered. For this purpose, the cursor has to be moved to the time of the event and the right mouse button has to be clicked. Then the Set Marker box is opened, into which the event text may be entered. After confirmation by OK, the red vertical line is generated and whenever the cursor comes close to this line the event text is displayed for 10 sec. The event marker is saved in the *.xpim file.

6.3 Light Curve window

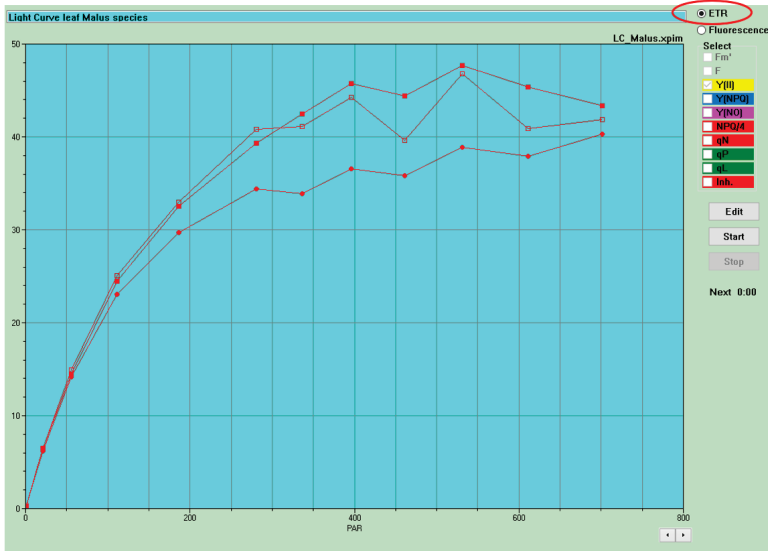

Fig. 30: Light Curve window displaying the ETR-parameter of Light Curves derived from 3 AOIs covering different areas of a *Malus* leaf

A **Light Curve** consists of a series of illumination steps, at the end of which the effective PS II quantum yield as well as several other parameters are determined with a Saturation Pulse. Either the **ETR parameter** or the other **Fluorescence parameters** can be displayed. The x-axis corresponds to incident PAR, as defined by the previously determined PAR list. The current PAR list can be viewed under Options/PAR-List (see section 7.3). The definition of ETR is:

$$ETR = 0.5 * Y(II) * PAR * 0.84 \mu\text{equivalents } m^{-2} s^{-1}$$

(see also section 6.1.1.10 page 54). Although ETR Light Curves resemble conventional light response curves, it should be realized that the illumination periods normally are too short to assure true steady state conditions. Often ETR Light Curves are distorted by

dark-to-light induction effects. The latter can be minimized by using pre-illuminated samples or by pre-illuminating the samples with, e.g., 3 min of $50 \mu\text{mol quanta m}^{-2} \text{s}^{-1}$.

The maximal ETR reached upon light saturation of photosynthetic electron flow at high PAR values strongly depends on correct determination of rather small ΔF values induced by the saturation pulses. It is important to realize that close to light saturation an underestimation of F_m' by a few percent will induce a large underestimation of $Y(\text{II})$ and, hence, also of ETR.

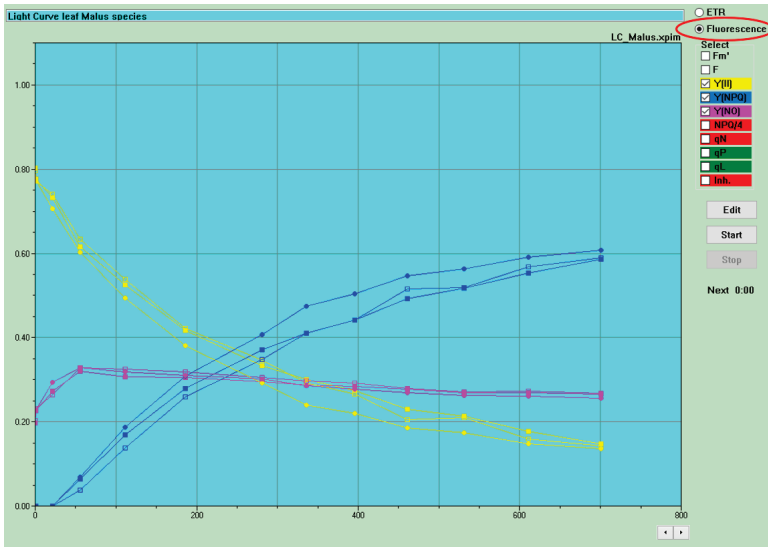

Fig. 31 Light Curve window showing Light Curve parameters derived from 3 AOIs, for which the averaged values of the PS II quantum yield parameters $Y(\text{II})$, $Y(\text{NPQ})$ and $Y(\text{NO})$ are displayed.

More detailed information on the physiological reactions taking place during the course of a Light Response Curve can be derived from the Light Curves of the various **Fluorescence parameters**. As illustrated in Fig. 31 on page 79, with increasing PAR the **$Y(\text{II})$** parameter continuously decreases, whereas the **$Y(\text{NPQ})$**

<input checked="" type="radio"/> ETR	<input type="radio"/> ETR
<input type="radio"/> Fluorescence	<input checked="" type="radio"/> Fluorescence
Select	Select
<input type="checkbox"/> Fm'	<input type="checkbox"/> Fm'
<input checked="" type="checkbox"/> F	<input checked="" type="checkbox"/> F
<input checked="" type="checkbox"/> Y(II)	<input checked="" type="checkbox"/> Y(II)
<input type="checkbox"/> Y(NPQ)	<input type="checkbox"/> Y(NPQ)
<input type="checkbox"/> Y(NO)	<input type="checkbox"/> Y(NO)
<input checked="" type="checkbox"/> NPQ/4	<input checked="" type="checkbox"/> NPQ/4
<input checked="" type="checkbox"/> qN	<input checked="" type="checkbox"/> qN
<input checked="" type="checkbox"/> qP	<input checked="" type="checkbox"/> qP
<input type="checkbox"/> qL	<input type="checkbox"/> qL
<input type="checkbox"/> Inh.	<input type="checkbox"/> Inh.

parameter shows an almost antiparallel increase, and the **Y(NO)** parameter is almost constant. The curves for the 3 selected AOIs are similar, but not identical. The three quantum yields always add up to a total of 1. Their relative values give important information on the partitioning of excitation

energy between photochemical utilization, Y(II), regulated heat dissipation, Y(NPQ) and unregulated heat dissipation.

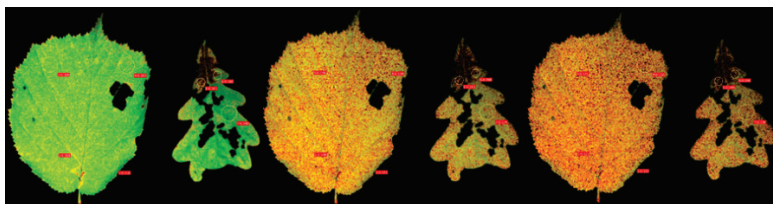
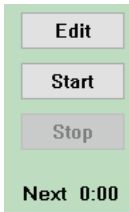



Fig. 32 Images of three light levels of a Light Curve: AL 5, 9 and 11.

For a better overview, in the example Fig. 33 page 84, not all available fluorescence parameters are displayed.

The user can choose between the display of **ETR** and the display of the other **Fluorescence** parameters. The display of ten different fluorescence parameters is possible. To display a particular parameter the corresponding check box must be checked. The parameters Fm', F, Y(II), Y(NPQ), Y(NO), NPQ/4, qN, qP and qL were already described in detail (see section 6.1.1). In principle, all fluorescence parameters may be displayed at the same time.



The display of data in the light curve window requires at least one AOI to be defined. If this is not the case, a warning will be displayed. A light curve is started with the Start button and can be stopped at any time with the Stop button. The recording of a light curve is a new record. Therefore, if the previous record has not already been saved, the user will be asked "Save previous record? Furthermore, as Light Curves are often measured with pre-illuminated samples, the user is asked "Do you want to keep the previously determined F_0 , F_m ? When recording a light curve, the number of the current illumination step is displayed in the Step box. Next refers to the remaining time until the next measurement (i.e. application of the next saturation pulse).

Clicking Start, the ETR scale limit is automatically set to 50; this can either be changed manually or using the **Autoscale**  icon.

Above the Light Curve window, the time and date of the recording are documented. The user can write a short comment



into the “**text field**”, which is saved together with the Light Curve Record. This text can also be entered or modified in View mode. The same text is automatically written into the corresponding text field above the Report file (see section 6.4 page 84).

After termination of a Light Curve recording, the software switches to **View mode**. Then the Light Curve Record can be saved using the **Save** icon (below Light Curve window).

In View mode an extensive analysis of the vast amount of information stored during the recording of the Light Curve can be made.



99 differently shaped AOIs are available for a single record and thus, in principle also a maximum of 99 Light Curves can be created and analyzed in parallel.

When the **AOI button** is pressed, the AOI window is opened, which shows in its bottom part a list of all AOIs that previously were defined in the Image-window. By clicking a particular number, the corresponding AOI is selected for data display in the Light Curve window. The data of several or all AOIs can be superimposed. In the top part of the AOI window, the data point symbols of the selected AOI number are shown. Examples are given for 4 out of 7 selected AOIs and 7 out of 7 selected AOIs being active for display, respectively.

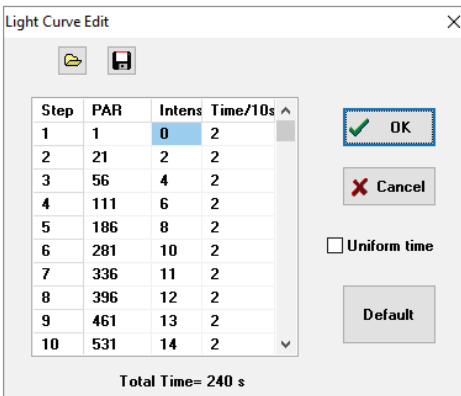

When the **Edit-button** is clicked, a separate window is opened, in which the user may **define the Light Curve parameters**, i.e., the number of illumination steps, the Intensity-setting at each step and the step length. **Up to**

20 different illumination steps can be defined. To modify one of the current settings (Intensity or Time/10 s), it first has to be selected by cursor/left mouse click and then the modified setting has to be entered. Please note that the PAR values for the selected Intensity settings are derived from the PAR list (see Options, chapter 7). The change becomes effective following the next

mouse click. When the **Uniform time** box is checked, the last entered time setting will be applied for all steps as soon as the Time/10 s cell of another step is clicked. When the **Default** button is pressed a Standard Light Curve featuring 12 Steps is defined, which has proven to give good results with “normal leaves”. This Standard Light Curve is terminated at intensity setting 16 (approximately $700 \mu\text{mol quanta m}^{-2} \text{s}^{-1}$ PAR). In practice, it rarely makes sense to go beyond this intensity setting, as the effective quantum yield becomes rather low and the noise in Yield-determination correspondingly high. To **terminate a Light Curve**, a **zero (0)** has to be entered in a Time/10 s cell. The Light Curve will then stop at this 0-cell.

In some applications it may be of interest to record a Light Curve with PAR values first increasing until saturation is reached and then decreasing again, to evaluate the capacity of the sample to recover from light saturation. Such an “**Up-Down Light Curve**” can be readily programmed by the user, e.g., by creating a list with the light intensity settings 0, 2, 4, 6, 8, 10, 12, 14, 16, 14, 12, 10, 8, 6, 4, 2, 0.

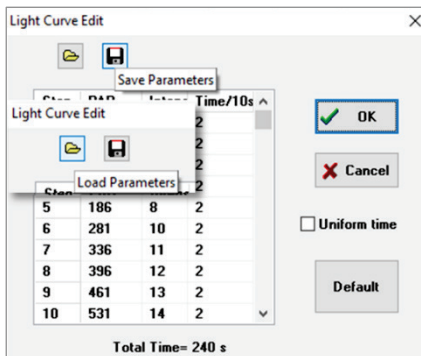

The Light Curve Parameters defined under Edit can be saved in an **lcp-file** from which they can be reloaded at any later time. In this way, different sets of Light Curve parameters can be optimized for different types of plants (e.g., sun and shade plants) and called up readily without losing much time. The lcp-files are saved in the Data-directories of the various Measuring-Heads.

6.4 Report window

In the Report window the data of the current **Record** are displayed in form of columns of parameter values. These lists can be transferred to spread sheet programs, like Excel. At the top of the Report window, the user can write a comment in a text field. The same text automatically is written into the corresponding text field above either the Kinetics or Light Curve window depending on the window in which the measurement was recorded. Alternatively, the text can also be written into the corresponding text field above the Kinetics or Light Curve windows and will then automatically appear in the text field above the Report.

Date	Time	No.	PAR	F1	F2	F3	F4	Fm1	Fm2	Fm	qP3	qP4	ETR1	E
17.08.22	10:49:09	1	0	0.0987	0.1134	0.0997	0.0826	0.4892	0.5430	0.	33	1.003	1.002	...
17.08.22	10:49:31	2	1	0.1163	0.1325	0.1173	0.0992	0.4922	0.5435	0	58	0.958	0.954	0.3
17.08.22	10:49:51	3	21	0.2111	0.2224	0.1955	0.1740	0.3710	0.3842	0.	31	0.594	0.572	3.8
17.08.22	10:50:11	4	56	0.1603	0.1662	0.1427	0.1261	0.2478	0.2532	0.	1	0.562	0.542	8.3
17.08.22	10:50:31	5	111	0.1339	0.1437	0.1251	0.1095	0.1940	0.2077	0.16		0.524	0.490	14.4
17.08.22	10:50:51	6	186	0.1396	0.1574	0.1369	0.1158	0.1862	0.2043	0.172		0.359	0.334	19.5
17.08.22	10:51:11	7	281	0.1383	0.1540	0.1334	0.1163	0.1686	0.1867	0.1642		1.332	0.297	21.2
17.08.22	10:51:31	8	336	0.1383	0.1554	0.1344	0.1163	0.1657	0.1843	0.1608		393	0.259	23.3
17.08.22	10:51:52	9	396	0.1378	0.1549	0.1349	0.1168	0.1623	0.1818	0.1603	0.	33	0.238	25.0
17.08.22	10:52:12	10	461	0.1369	0.1554	0.1354	0.1173	0.1588	0.1804	0.1584	0.	1	0.236	26.8
17.08.22	10:52:32	11	531	0.1364	0.1564	0.1359	0.1188	0.1554	0.1779	0.1564	0.1		0.196	27.4
17.08.22	10:52:52	12	611	0.1354	0.1574	0.1364	0.1188	0.1510	0.1745	0.1535	0.1		0.179	26.6
17.08.22	10:53:12	13	701	0.1339	0.1584	0.1373	0.1202	0.1476	0.1730	0.1520	0.1	7	0.148	27.3

Fig. 33: Report window showing part of the Record of a Light Curve. To the right of the table is the AOI selection button (marked red).

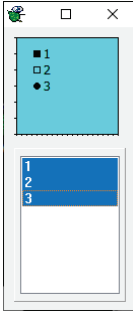

When the AOI button is clicked the numbers of the presently defined AOIs are shown. A maximum number of 100 AOIs can be defined in one measurement, each of the selected parameters will also generate the same number of columns in the report table. The data derived from these AOIs will be displayed in the Report window. The active AOIs can be (de)selected by a mouse click.

In the upper box the symbols associated with each AOI are shown. These symbols are used for graphical representations of these AOIs in the Light Curve (or Kinetics) window. Under **Select** it is possible to choose the fluorescence parameters to be listed in the Report.



Together with a Record also a **Comment File** can be saved, which is stored as a txt-file under the same name as the corresponding xpim-file (PAM image file).

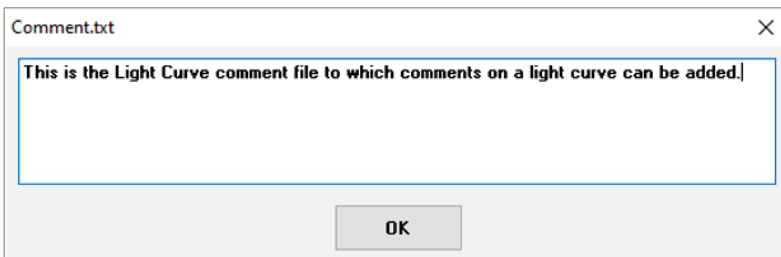

This comment file can be added or edited at any time in View mode and will be automatically saved as *.txt file together with the corresponding xpim file. Considering the vast amount of data which can be collected with the HEXAGON-IMAGING-PAM under largely different measuring conditions, this comment file is of considerable importance for the later assessment of the results.



Clicking the export icon will start a routine for exporting the data in the report file as filename.csv (a semicolon is

used as column separator). These *.csv files can be imported into external spreadsheet programs, such as Excel. Please note that the exported report corresponds to the selection of AOIs, and fluorescence parameters displayed in the report window.

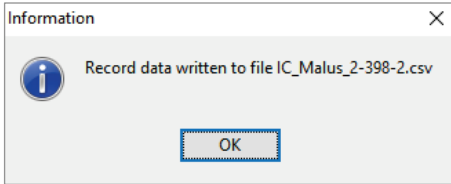

After clicking OK the Record (with the information specified in the Report window) is first transferred to the

file `xpim-filename.csv` into the ImagingPam data directory. From there it can be imported into other programs, like **Excel**.

If Excel is installed on the PC, the Report-data are in most cases automatically opened in Excel when `filename.csv` in the ImagingPam directory is double clicked.

Settings: mi2, mf1, ai3, aw0, icoff, g17, d3, si10, sw6, bo-, rg1, fmf1.000, al:

Below the report window the settings are listed in abbreviated form (see the figure above), which apply to the conditions of measurement No. 1 of the given record.

The meaning of the abbreviations is as follows:

- mi Measuring light intensity
- mf Measuring light frequency
- ai Actinic light intensity
- aw Actinic width
- icmax status of Image Correction
- g gain
- d damping

si	saturation pulse intensity
sw	saturation pulse width
fmf	Fm Factor
ff	F Factor (not applied under standard settings, see section 6.5.11 page 100 for explanations)
fmnf	Fm Normalization Factor
mifo	measuring light intensity for Fo measurement
gfo	gain for Fo measurement
mifm	measuring light intensity for Fm measurement
gfm	gain for Fm measurement
foav	number of Fo averages (the last 6 items apply only for the MAXI- and MICROSCOPY-versions, if the Special SP-Routine is activated)

6.5 Settings window

The Settings window shows all instrument settings, that can be modified by the user, and in Measure mode also provides information on the battery status (which is an obsolete information in the HEXAGON-IMAGING-PAM).

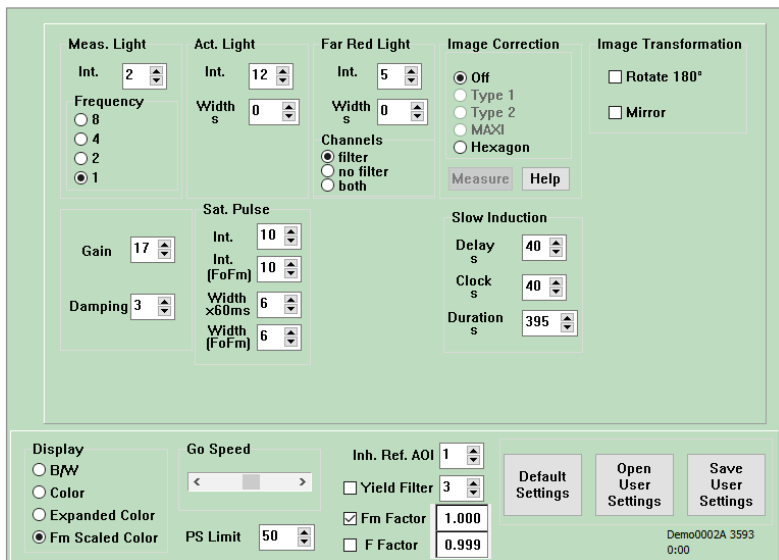
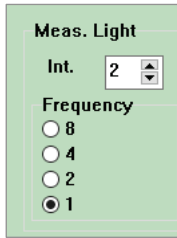

Fig. 34: ImagingWin user interface with Settings window being selected

The Settings window with standard settings is depicted in Fig. 34. Standard settings can be reinstalled at any time by clicking the Default Settings button. The Settings define the different light source intensities: Meas. Light, Act. Light, Far Red Light and Sat. Pulses as well as the Slow Induction protocol and several other parameters related to image analysis.

6.5.1 Light paramters

The HEXAGON-IMAGING-PAM features four different types of light: **Measuring Light**, **Actinic Light**, **Far Red Light** and **Saturation Pulses**. Except for the Far Red light, all three types of light are derived from the same source, the **LED Illumination Unit**; the Far Red LEDs represent a separate set of LEDs in this unit.



The **Measuring Light** is pulse modulated. It consists of relatively short (in the order of 100 μ sec) LED pulses. While these pulses are quite intense, they are applied at a relatively low repetition rate (frequency) of 1 to 8 Hz and, hence, do not have much actinic effect. The Measuring Light is automatically switched on after the start of the program. It can be manually switched off/on via the **ML** check box (see section 5.3). Its **Intensity** and **Frequency** can be set by the user. Standard settings are Intensity 2 and Frequency 1 (in combination with Damping 3) for the HEXAGON-IMAGING-PAM. For these settings the actinic effect of the Measuring Light is negligibly small. The Meas. Light Int. determines the amplitude of the fluorescence signal. Normally a signal amplitude of 150 - 200 units is optimal, assuming a maximal increase of the fluorescence yield during a Saturation Pulse by a factor of 4 - 5. Signal saturation occurs at 1000 units. A certain level of noise has to be accepted; a noise level, which can be modified by changing the Damping (see section 6.5.2 page 91). When dealing with weakly fluorescent objects (like algae suspensions in a black multiwell plate) a Special SP-Routine is provided, which involves an automated switching to a high setting of the Meas. Light Int. in combination with a lowered Gain-setting. In this way, the Signal to Noise ratio of F_m , F_m' , F_v/F_m and $Y(II)$ measurements can be considerably enhanced. At a given Meas. Light Int. setting the amplitude of the fluorescence signal can be adjusted by the Gain (see page 91). A Meas. Light Int. up to setting 20 can be selected. In this way, also weakly fluorescent objects can be imaged. It should be kept in mind, however, that with objects showing a light-induced fluorescence increase part of this increase will already occur during a single Measuring Light pulse, if the Meas. Light Int. is too high. In that case, the F-value will be

overestimated, and the saturation-pulse-induced fluorescence increase as well as the PS II quantum yield, F_v/F_m or $Y(II)$, will be underestimated. In principle, it is possible to correct for this effect by the **F Factor** (see below).

The **Actinic Light** drives photosynthesis. It is switched on manually via the **AL** check box or the **AL+Y** button (see section 5.3). The **Intensity** and the **Width** of actinic illumination can be defined by the user (Int. setting). When the Width is set to 0, actinic illumination will not be terminated until manually stopped by the user by unchecking the AL check box. One out of 20 settings of Act. Light Int. can be selected. The PAR-value corresponding to a particular setting is shown in the PAR-field when Actinic Light is switched on (see section 5.3). The list of PAR-values corresponding to all intensity settings can be viewed and edited under Options/PAR-List (Menu at the upper edge of the user interface, see chapter 7).

Far Red Light (FR) can be applied for the F_o' determination or for State transition experiments with the HEXAGON-IMAGING-PAM. It can be turned on manually via the FR check box at the bottom of the basic ImagingWin window or the F_o' button for direct determination of the current F_o' value. The Intensity and the Width of far red illumination can be defined by the user (Int. setting). When the Width is set to 0, FR illumination will not be terminated until manually stopped by the user by unchecking the AL check box. For the F_o' determination there is a fixed timing protocol that only allows to change the intensity. One out of 20 settings of Act. Light Int. can be selected.

Sat. Pulse	
Int.	10
Int. (FoFm)	10
Width x60ms	6
Width (FoFm)	6

Saturation Pulses (SP) are applied for determination of the maximal fluorescence yield (F_m or F_m'). Also, the fluorescence yield, F_t , observed briefly before triggering of the SP is assessed. By application of an SP a **Measurement** is defined, with the resulting data being saved in the buffer memory. Ten **Intensity** settings of SP are available, with the maximal setting 10 being standard. In most practical applications the best results are obtained with the maximum SP intensity.

During a Saturation Pulse the LEDs are driven at very high currents, which leads to a temperature increase of the light emitting chip. Therefore, the intensity of the emitted light is transiently lowered by approximately 5 %. This inevitably results in a corresponding decrease of the intensity of the Measuring Light, which is driven by the same LEDs, thus causing an underestimation of the F_m value measured during a Saturation Pulse. This effect can be compensated for by the F_m Factor (see below).

“Int.” applies to SPs triggered for effective quantum Yield measurements ($Y(II)$) and “Int. (FoFm)” settings apply when no actinic illumination is switched on.. In these situations, normally lower intensities for the SP are already sufficient for closing the PSII reaction centers.

The **Width** of Saturation Pulses can be changed from 240 to 840 ms (4 x 60 ms to 14 x 60 ms), standard **Width** of Saturation Pulses is 720 ms (12 x 60 ms).

6.5.2 Gain and Damping

The **Gain** determines the amplitude of the **fluorescence signal**, F_t , at a given setting of the Measuring Light Intensity (see

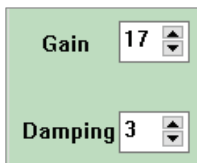

section 6.5). Twenty settings are available, with standard setting 17 for the IMAGING-PAM devices. The Gain should be set in such a way that in the absence of actinic illumination the fluorescence amplitude ($F_t =$

F_o) is in the range of 150 - 200 units.

When dealing with weakly fluorescent objects (like algae suspensions in black multiwell plates) a Special SP-Routine is provided, which involves automated switching to a high setting of Meas. Light Int. at lowered Gain-setting (see section 6.5.2 page 91). In this way, the Signal to Noise ratio of F_m , F_m' , F_v/F_m and $Y(II)$ measurements can be considerably enhanced.

With the help of the **Damping** and averaging time for the recorded images is set. Higher damping values significantly reduce the signal noise at high **Gain** levels, but also slows down the response time of the fluorescence signal.

Five settings (0 - 4) are available, with the standard setting being 3. It has to be considered that the time resolution not only depends on Damping, but on the frequency of the Measuring Light as well (see section 6.5.1). Hence, to see rapid changes in the F_t -image, e.g., when moving a sample, both low Damping and high Measuring Light frequency settings have to be selected. Live Video mode (see section 6.1.2.2), where near-infrared instead of blue light is applied, offers an alternative. For this application, Damping can be low and Measuring Light frequency high without having an actinic effect. Therefore, Live Video mode is best suited for positioning samples in the field of view and for focusing images.

6.5.3 Slow Induction parameter

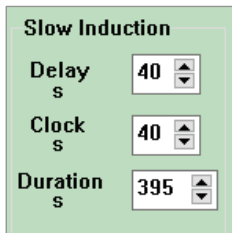

Slow Induction	
Delay s	40
Clock s	40
Duration s	395

The **Slow Induction Parameters** are applied to recordings of preprogrammed dark-to-light **Induction Curves** in the **Kinetics** window. After clicking Start the automatic F_0 , F_m -determination is triggered (see section 6.2) and then some time is given for the fluorescence yield to decline back to close to the original F_0 -level (re-oxidation of Q_A^-), before the Actinic Light is switched on. This **Delay**-time can be defined by the user, with the default value being 40 s. The **Clock**-time determines the time interval between repetitive Saturation Pulses, with which F and F_m' are determined. At a given duration of the actinic illumination, the Clock-time defines the number of measurements made (saturation pulses applied) during an Induction Curve recording. The **Duration**-time corresponds to the overall length of a recording, including the Delay-time and the actinic illumination time. The recording of a standard Induction Curve (using default settings: i.e., **Delay** is 40 s, **Clock** is 20 s and duration is 315 s) involves a total of 15 measurements, with the first corresponding to the F_0 , F_m -determination and the remaining 14 carried out after the actinic illumination is switched on.

6.5.4 Image Correction

For a high signal yield, the lens should always be operated with the aperture wide open. This can cause shading towards the edge of the image (edge light fall-off), which is called a vignette.

To compensate for this effect, correction images can be measured using a sample that has uniform fluorescence emission over the

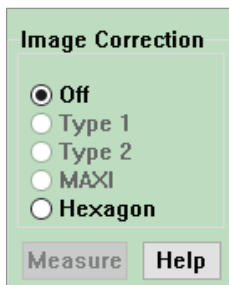

entire imaged area. This can be done with normal white printing paper, which emits enough fluorescence at high Measuring Light Intensity. This paper will emit sufficient fluorescence to produce a good quality fluorescence image when measured at a high gain setting.

Correction images must be determined under identical optical conditions that are also used for the experiments that shall be corrected. For the HEXAGON-IMAGING-PAM this is particularly relevant for the **working distance**, as the inhomogeneities due to differences in the Measuring Light intensity are minimal at a 19 - 21 cm distance between the exit plane of the LED-Array and the sample plane.

For the HEXAGON-IMAGING-PAM the working distance is fixed at an **optimal 20 cm** (standard distance). Also, the default PAR-list containing the factory values has been determined for this standard distance (see chapter 7). Therefore, unless there are compelling reasons to do otherwise, the standard working distance of 20 cm should be used.

For the HEXAGON-IMAGING-PAM four different correction images can be stored: **Type 1**, **Type 2**, **Maxi** and **Hexagon**.

All these correction images are equivalent so that different corrections could be stored for different situations.

During measurement, the correction image is processed directly with the image data and cannot be corrected afterwards.

To **determine the “Image Correction”** please proceed as follows:

- set the optical conditions under which the actual measurements are going to be made (working distance, focusing position, see above)
- select Type 1, Type 2, MAXI or HEXAGON (under Settings: Image Correction)
- place at least two layers of white paper (e.g., folded DIN-A4) in the sample plane
- put the image somewhat out of focus to avoid imaging fine structures of the white paper tissue
- press “Measure” (found under Settings: Image Correction)

The measured correction image will be saved until it is overwritten by a new measurement. The correction images will remain valid as long as the same optical parameters apply (LED Illumination Unit, working distance, focusing position, camera objective lens).

While the Image Correction can compensate for heterogeneities in the Measuring Light intensity, the corresponding heterogeneities in the Actinic Light intensity unfortunately cannot be corrected. In principle, higher PAR values tend to induce seemingly lower values of $Y(II)$ and seemingly higher values of $Y(NPQ)$ (see section on Light Curves 6.3). Maximal deviations of PAR values from the mean value are small (not exceeding 7%) and, hence, can be ignored in most applications.

6.5.5 Image Transformation

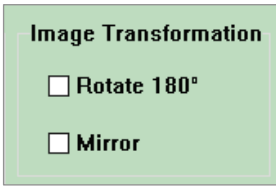
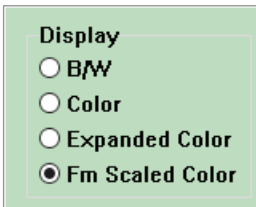

Image transformation can be used to change the way images are displayed. This allows the camera to be positioned relative to the user.

Images can be rotated by 180° or mirrored along the vertical midline. Default settings (**Rotate 180°** and **Mirror** boxes not checked) are used for the standard configuration, with the camera pointing downwards and its wide side pointing towards the user.

For example, in a special application where the probe is pointing upwards, moving a sample left and right (or up and down) would cause opposite changes to the displayed image. In this case it would be appropriate to check both Rotate 180° and Mirror.

6.5.6 Display parameters



The user may choose between four different types of image **Display**.

B/W: black-and-white; gray scale, ranging from black through shades of gray to white. This scale normally provides less contrast than a false color scale. At the bottom of the scale a cut-off is applied, which transforms all pixel values ≤ 0.040 into zero (black) for the sake of background noise suppression (see below).

Color: standard scale of false colors, ranging from black (pixel values ≤ 0.040) via red, yellow, green and blue to purple (0.999). At the bottom of the scale a **cut-off** is applied, which transforms all pixel values ≤ 0.040 into zero (black). This filter suppresses the background noise and gives optimal contrast

between leaf area and background. Even a non-fluorescent background area gives a weak signal due to unavoidable noise and some reflected leaf fluorescence. While the position of the cut-off filter is fixed under Color-display, it can be shifted under Expanded Color/Analysis (see below).

Expanded Color: Expanded Color can be activated in **View mode**. When selected, the Low and High cut-off limits defined by the user under **Analysis** (see section 6.1.2.5) become effective. All pixel values below the Low-limit are displayed in black and all pixel values above the High-limit are displayed in white. For pixel values within the cut-off limits, the same false color scale as for the standard Color display is used (from black via red, yellow, green and blue to purple).

With Low and High limits approaching each other, smaller differences in pixel values give different colors. This will increase contrast. On the other hand, it is also possible to decrease or completely remove the Low cut-off limit, which under normal Color-display by default is set to 0.040.

Fm Scaled Color: The Fm Scaled Color can be activated in **View mode**. It emphasizes structures with high fluorescence yield and suppresses structures with low fluorescence yield. As the fluorescence yield depends on the angle of incidence of the measuring light, Fm Scaled Color images give a 3-D impression.

When Fm Scaled Color is active, the pixel intensities (see information on Brightness in the upper right corner of the Settings window) are scaled relative to Fm (or Fm'), if the displayed parameter involves assessment of Fm (or Fm') with a saturation pulse.

The fluorescence parameters, images of which can be determined with the HEXAGON-IMAGING-PAM, can be divided into two

groups: 1) directly measured parameters like F_o , F , F_m and F_m' ; 2) derived parameters like F_v/F_m , $Y(II)$, NPQ etc. The latter are based on ratios of the directly measured parameters and, hence, lack information on the fluorescence yield. This function is accessible in **View mode** and cannot be used in Measure mode.

6.5.7 Go Speed

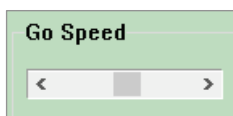

The **Go Speed** refers to the rate with which consecutive (previously captured) images (for example in the course of an Induction or Light Curve experiment) are displayed when the **Go-function** is activated in **View mode** (see section 5.2). At maximum speed spatiotemporal variations of fluorescence parameters can be presented in a similar way as in a video movie. On the other hand, lower speeds are required to evaluate the observed variations. For high-speed display of $Y(II)$ -images the **Yield Filter** (see section 6.5.10 page 99) should be **inactivated**.

6.5.8 PS Limit



The estimated rate of photosynthetic electron transport, PS, is calculated according to the equation:

$$PS = 0.5 * Y(II) * PAR * Abs. \mu\text{equivalents } m^{-2} s^{-1}$$

(see also section 6.1.1.10)

To display images of this parameter on a false color scale ranging from 0 to 1, the PS value is divided by a number, which corresponds to the expected limit of maximal PS, the **PS Limit**. The **standard setting is 50**, which means that the pixel value 1 is reached when $PS/50 = 1$. Limits of 50, 100, 150, 200 and 250 can be selected.

6.5.9 Inh. Ref. AOI

A screenshot of a software control panel. It features a green rectangular background. On the left, the text 'Inh. Ref. AOI' is displayed in white. To the right of this text is a white input field containing the number '1'. To the right of the input field is a small vertical scroll bar with up and down arrows.

1

The image of the Inh. parameter is calculated pixel by pixel relative to Inh. Ref. AOI, which normally corresponds to a control AOI. An AOI number between 1 and 100 can be selected. The control AOI is set by default to 1 upon start of the program.

This parameter is particularly important for assessment of phytotoxicity using multiwell plates. The Inh. parameter describes the relative inhibition of the PS II quantum yield with respect to a control value (see also section 6.1.1.15 page 58):

$$Inh. = (Y_{control} - Y_{sample})/Y_{control}$$

6.5.10 Yield Filter

A screenshot of a software control panel. It features a green rectangular background. On the left, the text 'Yield Filter' is displayed in white. To the right of this text is a white input field containing the number '3'. To the right of the input field is a small vertical scroll bar with up and down arrows.

3

The **Yield Filter** suppresses noise in Y(II)-images, which is mainly due to noise in the Fm and Fm' images measured during the relatively short Saturation Pulses. The Yield-filter is effective in **View mode** only, i.e., when images are called up from the buffer memory (see section 5.2 page 40). Filter settings 0-5 are available, with the standard setting 3. Noise reduction is achieved by averaging the value of every individual pixel with those of a defined number of neighboring pixels. With increasing filter setting the number of pixels within an averaged domain increases (setting 1, 8 neighbors; setting 2, 24 neighbors; setting 3, 48 neighbors; etc.). This unavoidably leads to some loss in spatial resolution. Furthermore, depending on the noise structure, the averaged domains may form patterns which sometimes can be more disturbing than the original noise. Please note that the Yield-filter slows down the build-up of the Y(II) image. This may limit the

rate with which consecutive Y(II) images can be displayed using the Go-function (see section 6.5.7 page 98).

6.5.11 F Factor

F Factor The F Factor can be applied to compensate the actinic effect of the Measuring Light pulses, which tend to cause an overestimation of F_o or F and a corresponding underestimation of F_v and Y(II). The F Factor is always < 1 . It corresponds to the factor with which the measured F_o or F value must be multiplied in order to obtain correct values. In contrast to the F_m Factor, the F Factor is not an instrument parameter, and it cannot be assumed to be constant. It depends on the physiological condition of the sample and in particular on the redox state of the PS II reaction centers. In the case of, for example, DCMU-inhibited samples, already low measuring light intensities will be actinic. If the correct F_o in the absence of inhibitor can be determined separately, the F Factor may help to correct for this effect. Severely heat stressed plants in which a fraction remains reduced in darkness is another example of a situation where application of the F Factor may have practical value. In other cases, the user must decide for him- or herself, whether for a particular application the F Factor correction is advantageous or not. It cannot be recommended to be used for Light Curves. The F Factor check box is not active upon clicking Reset Settings (see section 6.5.12 page 103). It is also possible to **recalculate previously recorded data** based on a new F Factor defined by the user.

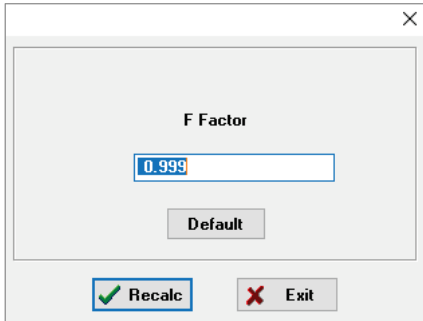

A new F Factor can be defined for the current Record in Measure as well as in View mode. In Measure mode, however, the F Factor has to be defined before the first measurement (normally an F_0 , F_m -determination). A

corresponding dialog window is opened by a left mouse click on the current value in the **F Factor** box. Alternatively, this window can also be opened via **Recalc** in the Menu (see section 7.4). The current value can be erased, and the new value written into the box. The new value is confirmed, and the previously measured data recalculated upon pressing the **Recalc** button or simply return follow insertion of the new F Factor. The new F Factor remains active until manually changed or reset to the standard value of 0.950 by clicking the Default button.

Note: Recalculation of data based on a new F Factor always applies to the whole Record. If the user tries to change the F-factor after F_0 , F_m -determination, there is a corresponding warning: **“For changing F factor start new record”**.

Two types of actinic effects of the Measuring Light can be distinguished:

- 1) Accumulation of closed PS II reaction centers due to repetitive illumination with Measuring Light pulses. This effect increases with Measuring Light intensity, pulse frequency and the extent of dark acclimation of the sample. It does not play a role, when the overall PAR is high during actinic illumination. Furthermore, in the case of the Imaging-PAM

even at the maximal ML Frequency there are relatively long dark times between ML pulses, so that under normal physiological conditions the accumulation of reduced primary acceptors in PS II is insignificantly small.

- 2) Closure of a significant fraction of PS II centers during each individual Measuring Light pulse. This effect increases with Measuring Light intensity and is favored by a large functional absorption cross section of PS II. Notably, it also occurs at minimal pulse frequency of the Measuring Light and does not become irrelevant during actinic illumination, as long as there are open PS II reaction centers. In experiments with the Imaging-PAM this effect can be quite significant, as a relatively strong ML pulse intensity has to be applied to obtain high quality images at the given low repetition rates (limited by transmission of large data volumes). The F Factor correction is essential when in experiments with weakly fluorescing samples a high Measuring Light intensity is chosen. In principle, the system sensitivity can be increased either via higher settings of Gain or *Meas.Light Int.* However, high Gain, also increases the noise. On the other hand, at high *Meas.Light Int.* the overestimation of F (or F_o) becomes rather large. As a first approximation, the effect increases linear with the intensity. Hence, when an increase from setting 1 to 2 results in an apparent 5 % increase of F_o , this will amount to about 20 % at setting 5.

The F Factor can be determined by the user for a particular type of sample and illumination conditions by measuring the F (or F_o) (a) at *Meas. Light Int.* setting 1 and high Gain setting (averaging over several measurements) and (b) at a higher *Meas. Light Int.* setting and lower Gain. For comparison, the data first have to be normalized at F_m' (or F_m). Once the F Factor has been determined, its use provides an elegant way for high quality

imaging of fluorescence parameters of weakly fluorescing samples, without sacrificing the correctness of the F (or Fo) measurement. However, the proper use of this correction factor requires some experience and background knowledge of the physiological background of the samples measured.

6.5.12 Reset Default Settings, Open or Save User Settings

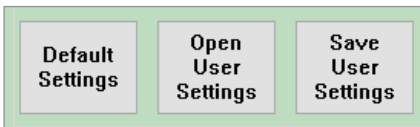

The buttons “Default Settings”, “Open User Settings” and “Save User Settings” facilitate the handling of setting adjustments. Upon clicking “Default Settings”, the standard factory settings are re-applied. The Default settings have proven optimal for imaging of fluorescence parameters of typical samples with the HEXAGON-IMAGING-PAM. Please note: the “Default Settings” button does not reset the PAR-List, Image Correction and Absorptivity adjustments.

The “Save” and “Open User Settings” buttons store and open individually preset settings. Please note these buttons also store or reopen the active PAR-List!

7 IMAGINGWIN - Menu Bar

The menu bar contains the File, Edit, Options, AL-List, Recalculate and Transect menus with the functions listed in their drop-down menus, as described in the following section.



7.1 File

7.1.1 Transfer FoFm

In View mode a Fo, Fm-measurement can be transferred to another .xpim file by clicking “Transfer FoFm” in the file menu. Data will be recalculated with the given parameter.

7.1.2 Using Skript files - Load Script/Run Script

There are two ways to load an existing or to create a new script file. The “load script” command in the file menu [Fig. 35](#) or click the load script file button in the bottom right corner:

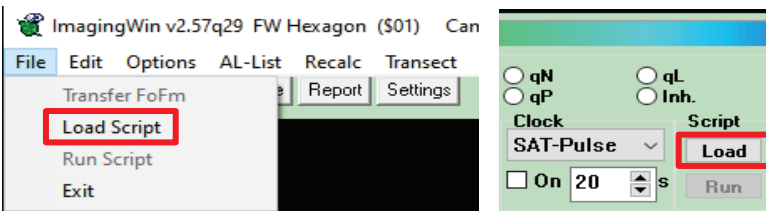

[Fig. 35](#) Scripts can be loaded via the File menu at the top of the window or via Load below the Image-window.

A new window opens that shows the available script files:

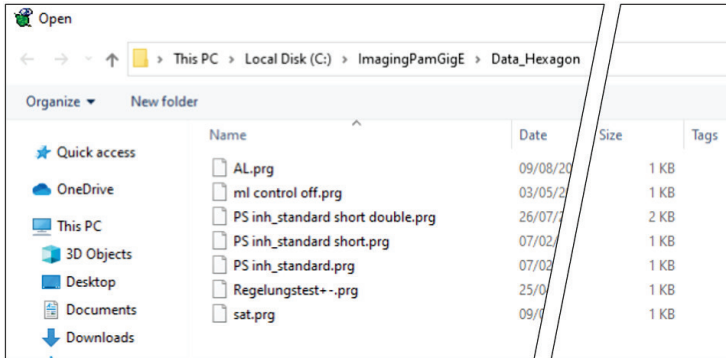

After choosing a file or entering a new file name and clicking “open” the editor window is opened:

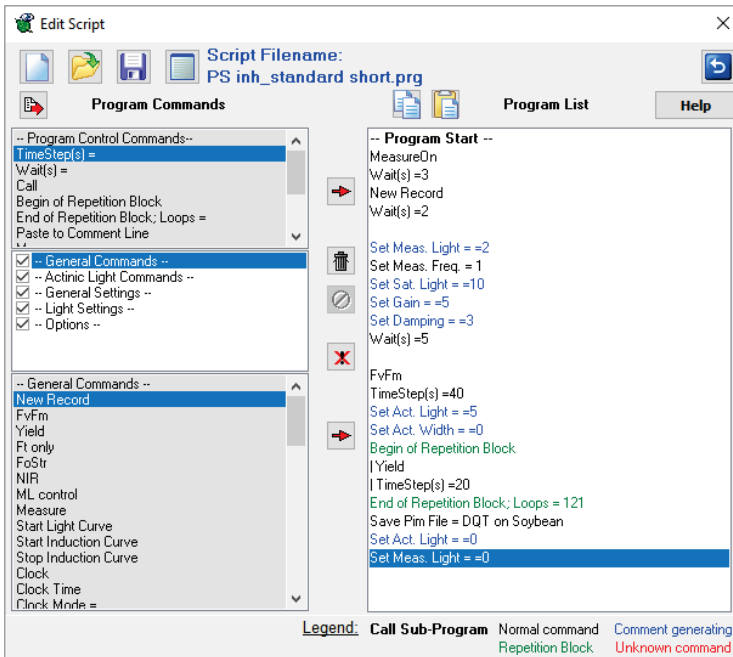

Script File: Open, New, Save, Comment & Back

Four command buttons are provided for the management of script files



New Script File. The command clears the <Script File Window> and prompts for a new script file name.



Open Script File. Click to open a stored script file with name format <filename.prg>. The default directory for script files is C:\ImagingPamGigE\Data_HEXAGON. Other directories can be defined using the Windows graphical user interface.



Save Script File. Saves <Script File> to the default or user defined directory.



Script File Comment. Clicking this icon displays the content of an editable text file called <filename.txt> which is associated with the script file <filename.prg>.

Editing Tools & Back



Copy Command. The command stores one or several lines of the current script file into the RAM clipboard. To execute the copy command, select one or several lines using the mouse cursor (Left click once to select one line). Hold down the <Shift> key and select the first and last line of a series of script file commands to select a group of connected lines. Hold down the <Ctrl> key to select several scattered lines. Click the <Copy Command> icon. The selected commands

are now available for pasting in the current or into another script file using the <Paste Command>.



Paste Command. To paste previously copied commands, select a line in the target script file and click the <Paste Command>. The pasted lines will be written below the selected line.



Insert Command. To insert a new command in the program list, select by a left mouse click a command line in the <Script File Window>, and then select by left click in the <Command Box> the command to be inserted. Clicking the <Insert Command> icon will place the new command below the line marked in the program list.



Delete Command. To delete a command line, select one or several commands as described above and click the <Delete Command> icon.



Undo Delete Command. Clicking the icon reverses the last <Delete Command>.



Disable/Enable Command. To disable command lines in the current script file, or enable previously disabled command lines, select command lines as described above and click the <Disable/Enable Command> icon.

On the left side of the script editor the available commands are listed, on the right-hand side the script program consisting of a list of command lines can be seen.

A command can be chosen by clicking on it. The transfer into the script listing is realized by double click on the command or by

marking followed by a click on the red arrow between both windows:

It is useful to define  first the basic starting settings of the experimental script like “Set Meas. Light =” until “Set Sat. Interval =” with which also “personal settings” can be defined. After the script has been executed, the script-defined values remain at this setting in the Settings window. For subsequent experiments the set values in the Settings window can be changed again manually or by another script.

After defining the basic settings, the experiment can be defined:

Program Commands:

TimeStep(s)	defines a waiting time after the last command. This command considers the time needed for the previous command (e.g., 800 ms for the Fv/Fm-determination). Using TimeStep the time distortion of very long scripts caused by the Wait(s) command can be avoided.
Wait(s)	Defines a waiting time after the last command independent of the command's duration.
Call	Imports and runs another script file as sub-program, returns to the running script when the sub-script ends.
Begin of Repetition Block	initiates a loop – enter the name of the loop and the number of repetitions. Each loop produces one or more lines in the report. The maximum length of the report is 999 lines – with, e.g., each

	saturation flash a new line in the report is written.
End of Repetition Block	Terminates a loop. Here the number of repetitions/loops is defined.
Paste to Comment Line	Enters a user-defined remark into the comment line of the report file.
Message	opens a message window, pauses the script till the message is confirmed by the user.
Remark	Inserts a user-defined remark that pops up during the run. This remark is not stored in the report file unless the command "Paste to Comment Line" is chosen.
Spacer	Inserts an empty line in the script file.
Exit	Quits ImagingWin software.

General Commands:

New Record	generates a new record (up to 200 Y(II) measurements possible).
FvFm	determines the maximum quantum yield (also called Fo, Fm).
Yield	triggers a saturation pulse (SP) for the measurement of the effective quantum yield.
Ft only	starts a measurement of Ft only – no saturating flash triggered.

FoStr	measures the current F value after 5 seconds of FR light application (AL is switched off during this time) and stores measured value as Fo' value.
Abs	Starts an absorptivity measurement. (Not available for HEXAGON.)
Measure	Switches the measuring light (ML) on.
Start Light Curve	Starts a Light Curve similar to the “start” button in the “Light Curve” tab. After the measurement is finished, the software automatically switches to view mode. The desired light curve protocol must be loaded beforehand on the Light Curve tab.
Start Induction Curve	Starts an induction curve similar to the “start” button in <i>Kinetics</i> tab. After the measurement is finished, the software automatically switches to view mode. The desired AL Intensity must be defined beforehand.
Stop Induction	Stops the automatic induction curve. Curve. System automatically switches off measure mode.
Clock	Switches on the clock timer.
Clock Time	Defines the period of the clock sequence.
Clock Mode	For selection of the Clock item. There is a choice of four different protocols: <i>SAT-Pulse</i> , <i>AL</i> , <i>AL+Yield</i> and <i>Ft only</i> . With an additional checkbox previously defined values can be restored
Load PAR File	Loads an alternative PAR list.

Load Pim File	Opens an existing xpim file (view mode). When switching to measure mode afterwards, the previous AOIs are retained.
Save Pim File	Saves the recorded *.xpim file under a user-defined name the default storage folder cannot be changed.
Save NIR File	Saves the recorded NIR images.
Export to Tiff File	Exports the recorded raw images as stacked b/w multi-Tiff File with 12-bit images.
Export to CSV File	Exports the Report table into a CSV file for further usage in e.g. Excel. Only values and AOIs that have been selected previously.
Export all to CSV File	Exports the Report table into a CSV file for further usage in e.g. Excel. All AOIs and all parameters included.
Select Image	Defines the image shown after completion of the Record.
Save Tiff Image	The currently shown image (Select Image command) is exported in Tiff format.
Save Jpeg Image	The currently shown image (Select Image command) is exported in Jpeg format.

Actinic Light Commands:

ML	Switches Measuring Light on/off (Intensity is set via <i>Set Meas. Light</i> command).
----	--

AL	Switches Measuring Light on/off (Intensity is set via <i>Set Act. Light</i> command).
Ext	Not available for HEXAGON-IMAGING-PAM.

General Settings:

Recording Mode	It can be chosen between the three recording modes Manual, Ind. Curve, Ind.+Rec.
Set Gain	Sets gain: enter “value” of the desired gain level. + or – “value” to raise or decrease gain by a desired number of steps.
Set Fm Factor	Not available for HEXAGON-IMAGING-PAM.
Set Damping	Sets damping: enter “value” of the desired damping level. + or – “value” to raise or decrease the Damping with respect to the currently set values.

Light Settings:

Set Meas. Light	Sets measuring light (ML) intensity: enter “value” of the desired measuring light intensity (ML) + or – “value” to raise or decrease the measuring light intensity with respect to the currently set values.
Set Meas. Freq.	Sets the measuring light frequency.

Set Act. Light	Sets actinic illumination (AL) intensity: enter “value” of the desired actinic illumination (AL) intensity level (“value” should equal one of the intensity levels of the light list) + or – “value” to raise or decrease the actinic light intensity with respect to the currently set values.
Set Act. Width	Sets actinic illumination (AL) width: enter “value” of the desired actinic illumination AL duration (in seconds), + or – “value” by which to raise or decrease actinic illumination duration (in seconds).
Set Sat. Light	Sets Saturation Pulse (SP) intensity: enter “value” of the desired SP intensity level, + or – “value” to raise or decrease the actinic light intensity with respect to the currently set SP Intensity values.
Set Sat. Width	Sets Saturation Pulse (SP) width: enter “value” of the desired SP duration (in seconds), + or – “value” by which to raise or decrease SP duration (in seconds). Can be adjusted in time increments of 60 ms

Options:

Mean Over AOI	The AOI evaluation mode can be switched with this command (see also section 7.2.3 page 115).
Detect by Fo	The mask covering areas with no variable fluorescence (Mean Over AOI option) is normally taken from the Fm measurement. For cases in which no initial SP shall be

applied, the mask may also be derived from the Fo image.

Show AOIs

If images without visible AOIs shall be exported.

Command lines can be selected and copied clicking the  icon.

The  icon pastes the copied lines below the cursor position.

Clicking the diskette icon saves the script file with a user-defined name as a *.prg file in the data folder of the directory for the PAM instrument used.

7.1.3 Exit

Exit quits ImagingWin.

7.2 Options Menu

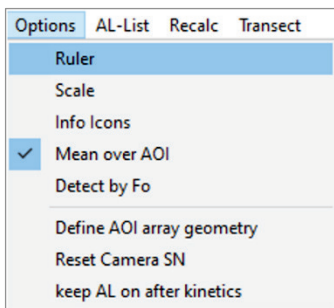

7.2.1 Ruler

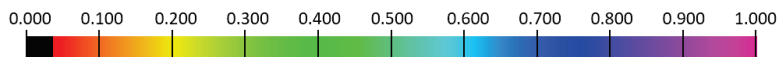

The Ruler, which shows numbers from 0 to 100, is placed above the false color scale reflecting values between 0 and 1.

Hence, the ruler may help to estimate the pixel value of a particular color. For example, yellow corresponds to pixel values around 0.2.

7.2.2 Scale

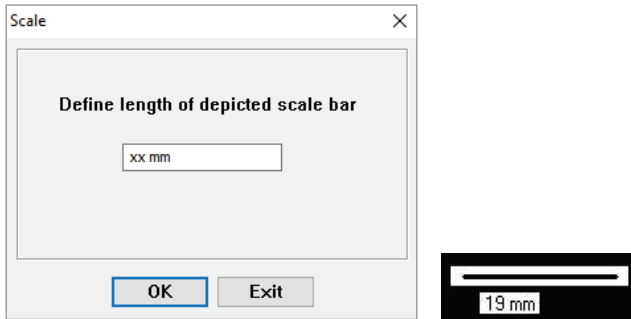

After clicking Scale, the Scale window is opened in which the user can define the length of the depicted scale bar. In the case of the HEXAGON-IMAGING-PAM, a scale width of xx mm is proposed, which in the Scale window has to be modified by the user. When confirmed by clicking OK, the scale width is written underneath the Scale bar. Please note that the Scale option can be applied in View mode only. The modified scale width will be saved when the program is closed.

7.2.3 Mean over AOI

Two different modes for analysis of the pixel values within an AOI can be selected under Options.

- 1) When "Mean over AOI" is enabled, the "Filled" checkbox applies (instead of "Limits" on the very right of the ImagingWin main window AOI selection).
- 2) When "Mean over AOI" is disabled, the "Limits" checkbox is activated (instead of "Filled" on the very right of the ImagingWin main window - AOI selection area).

“**Mean over AOI**” normally should be **enabled** with objects for which AOIs with close to uniform photosynthetic activity can be defined (e.g., leaf or well filled with algae suspension).

“**Mean over AOI**” should be **disabled** when the photosynthetically active object is “patchy”, so that it is difficult or impossible to define an AOI with homogeneous photosynthetic activity (e.g., patches of algae growing in a well).

Definitions:

“Mean over AOI” enabled: The pixel values over the whole area of the AOI are averaged and the average pixel value is displayed.

“Mean over AOI” disabled: Within the defined AOI only those pixel values are averaged for which $F_v/F_m > 0$. Hence, the displayed value corresponds to areas with photosynthetic activity only.

Filled: When enabled, the whole area of the AOI is “filled” with the color corresponding to the average pixel value, which works only when “Color” is selected under Settings/Display. When disabled, each pixel is displayed with the color corresponding to its individual pixel value.

Limits: When enabled, the pixel values in the photosynthetically active areas are averaged, whereas the non-active areas are displayed in black. In this way the limits of the photosynthetically active areas with respect to the non-active areas are emphasized.

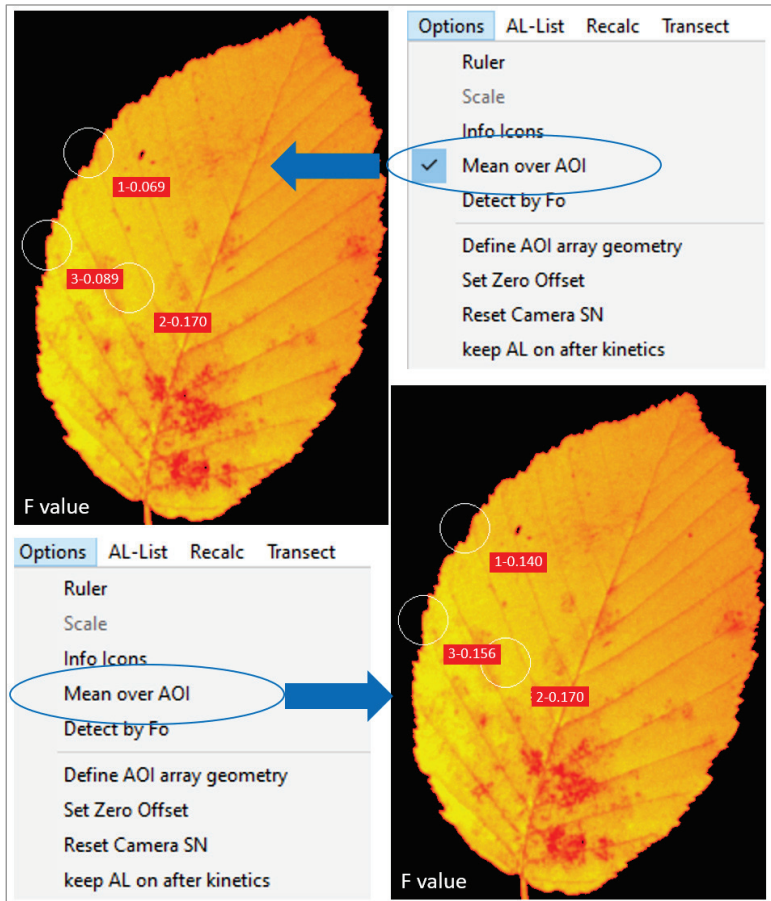
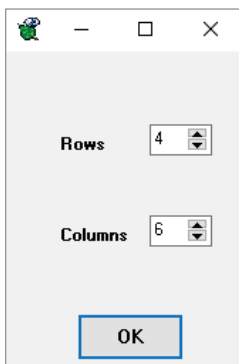

Fig. 36 Mean over AOI enabled (after an Fo, Fm determination): 0.069, 0.089, 0.170 (left – black pixels in AOI are also taken for mean value) and disabled 0.140, 0.156, 0.171 (right – Fo Fm determination masks black pixels)

7.2.4 Define AOI-array geometry



After clicking “Define AOI-array geometry” a window is opened in which the number of rows and lines of the array grid can be defined for, e.g., a multiwell plate. After confirmation by OK, this definition will remain valid until a new geometry is defined. Before an AOI array can be created, the position of this array within the overall image must be defined. This is done by defining AOIs in the **upper left** and **lower right** corners of the array.

7.2.5 Create AOI array:

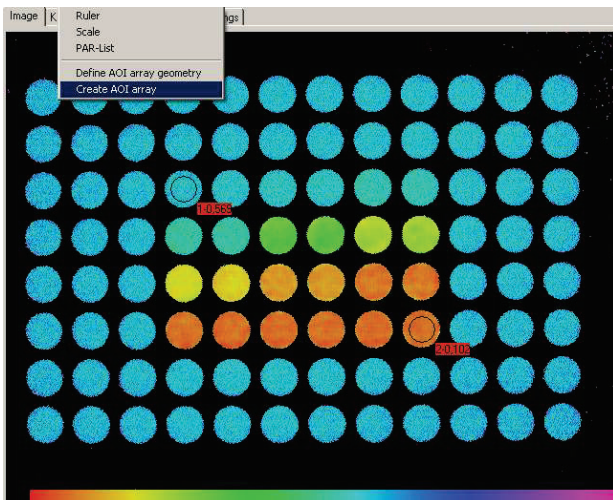

After the two corner AOIs are defined, the **Create AOI array Option** can be carried out and the corresponding array will be displayed after some delay (calculation time).

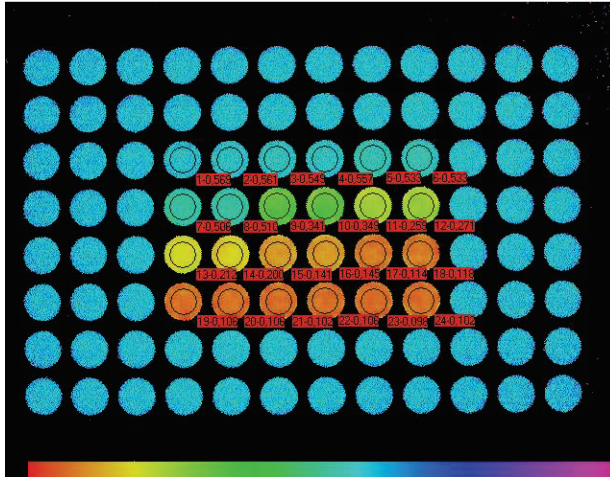

In the above example an array of 24 AOIs with 4 rows and 6 lines in the center of a 96 well microtiter plate was defined. While all wells were filled with aliquots of algae suspension, only to the 24 wells covered by the array increasing concentrations of the PSII inhibitor diuron were added, which causes decreasing values of Y(II).

7.3 AL-List

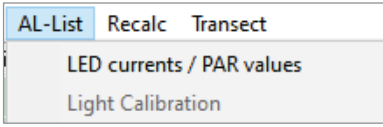

In the AL-List dropdown menu, actinic light (PAR) lists can be loaded, viewed and edited via LED currents / PAR

values. In combination with an Ulm-500 Light Meter & Logger also a Light Calibration routine can be made.

In the case that the HEXAGON-IMAGING-PAM was ordered together with a computer, the calibrated light list is already installed on the control computer (C:\ImagingPamGigE\Data_Hexagon). Should the software be installed on another computer, the supplied light list (LRLJxxxx.par) must be copied into the "Data" directory mentioned above. The light list supplied has been calibrated for the HEXAGON standard configuration with a working distance of 20 cm.

7.3.1 LED currents / PAR values

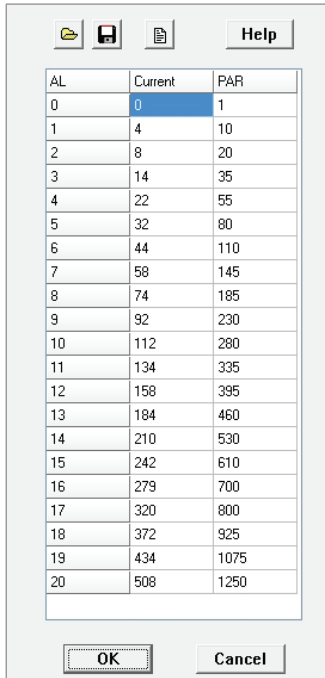

AL	Current	PAR
0	0	1
1	4	10
2	8	20
3	14	35
4	22	55
5	32	80
6	44	110
7	58	145
8	74	185
9	92	230
10	112	280
11	134	335
12	158	395
13	184	460
14	210	530
15	242	610
16	279	700
17	320	800
18	372	925
19	434	1075
20	508	1250

Clicking LED currents / PAR values opens the window displayed to the left.

“Open PAR-file” loads an existing *.par file.

“Save as PAR-file” saves the displayed PAR values in a .par file. A comment file giving information about this PAR-list can be added.

“Show comment file” displays the information stored together with the opened *.par file.

The Help button opens a text file with further information.

The PAR-List gives the LED current and PAR values for the Actinic Light intensity settings 0 - 20. **LED Current as well as PAR values may be edited.** Possible Current values range from 1 to 511. Changes in LED current values result in changes in LED light intensities. PAR values are given in $\mu\text{mol quanta m}^{-2} \text{s}^{-1}$. Editing the PAR values does not change the LED intensities, it changes the annotation of the actinic Light intensity. Different PAR-Lists apply to the various Measuring Heads. In the case of the MAXI-version, the Default PAR-List refers to the standard working distance of 18.5 cm between LED-Array Illumination Unit and sample plane. The listed values can be edited by the user and the edited list confirmed by clicking OK. A *default.par* PAR-List file with factory values determined under standard conditions for each measuring head version, is stored in the corresponding Data folder.

Although the **relative values** of Actinic Light intensities 0 - 20 do not vary between individual instruments, there may be some variation between instruments in terms of **absolute intensities** due to different charges of LEDs. Absolute Intensities can be determined with an ULM-500 Light Meter & Logger using the light calibration routine described in the next chapter.

When dealing with leaves, it has to be considered that the effective PAR at a particular setting, due to the pronounced light gradients within the samples, does not correspond to one value, but rather to a band of values with a Gaussian distribution around a central value. Therefore, differences between incident and effective PAR values may be expected. On the other hand, as most of the measured fluorescence originates from cells near the leaf surface, the observed light response will be dominated by the upper cell layers where the incident intensity is close to the effective intensity. These aspects have to be considered when comparing apparent electron transport rates derived from fluorescence measurements (ETR) reflecting mainly the activity of the upper cell layers with gas exchange rates reflecting the activity of the whole leaf. In contrast to chlorophyll fluorescence, the gas exchange response involves deeper cell layers with effective PAR being attenuated relative to incident PAR, but as well with photosystems acclimated to these lower light intensities.

7.3.2 Light Calibration

Automated Light Calibration requires an ULM-500 Light Meter & Logger with a PAR sensor, e.g., the LS-Cn for the HEXAGON-, MAXI- and MINI- version or the MC-MQS for the MICROSCOPY-version.

Please connect the ULM-500 to the computer before starting ImagingWin. “Ulm active” appears in the window title to show that ULM-500 - ImagingWin communication is enabled.

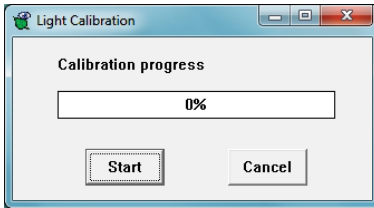
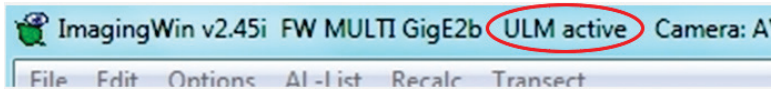

Clicking “Light Calibration” found under the **Options** tab in the Al-List menu a Light Calibration window pops up.

Place the microquantum sensor in the middle of the sample plane and make sure that it does not change its position during calibration. Then start the automatic calibration routine for the 20 actinic light intensities by clicking Start. If the calibration protocol is running it should not be interrupted. Please let the calibration run until it is finished before repeating it (if necessary).

A small cosine-corrected PAR sensor such as the Walz LS-C is recommended for the calibration measurement. It can simply be placed on the sample plane and due to its flat design, there is no need to pay attention to the correct height.

7.4 Recalc

Using the **Recalc Option** it is possible to recalculate the data of a given Record on the basis of correction factors for F_m (or F_m') and F as already described in the 6.5.11 page 100). Recalculation is always applied to the whole Record. It can be carried out in View- as well as in Measure mode. In Measure mode, however, this correction factor has to be defined/determined before the first measurement (normally an F_0 , F_m -determination). If the user tries

to change the F factor after F_0 , F_m -determination, there is a corresponding warning.

Recalculation is started upon clicking the **Recalc button**. When the **Default button** is clicked, the data are recalculated based on the Default value of the F_m Factor = 1.055 or the Default value of the F Factor = 0.950.

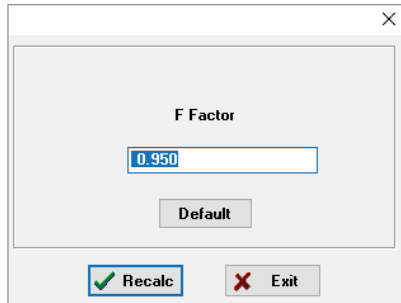

As the Recalculation is carried out in View mode, it is irrelevant whether under Settings the F_m Factor and F Factor checkboxes are enabled or disabled.

The possibility of recalculation of previously recorded data in View mode is particularly helpful, if at the time of the actual measurements there is uncertainty about the proper values of F_m and F Factors. In the case of Light Curves, for example, the data may be recalculated based on various F_m Factors to obtain a reasonably shaped saturation curve. A biphasic response curve without apparent saturation suggests that the applied F_m Factor is too high. If the response curve shows a maximum followed by a decline, this normally suggests that the applied F_m Factor is too low. Unless rather long illumination times at high intensity settings are applied, a genuine decline of ETR by photoinhibition is unlikely.

Application of an F Factor when measuring a Light Curve is problematic and cannot be recommended. As F values are increasing with PAR, the relative increase of F due to the individual ML pulses (see section 6.5.1 page 88) will decline. Therefore, application of a constant F Factor is bound to result in overestimation of ETR at high PAR. If Light Curves were recorded

with a F Factor being enabled, the data can be readily recalculated with F Factor = 1.

7.5 Transect

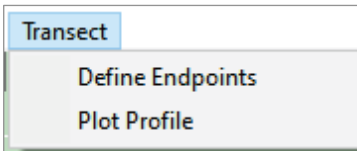

The **Transect Option** allows plotting of the pixel values of an imaged parameter along a previously defined line segment. In this way a profile of this parameter across a sample can be obtained.

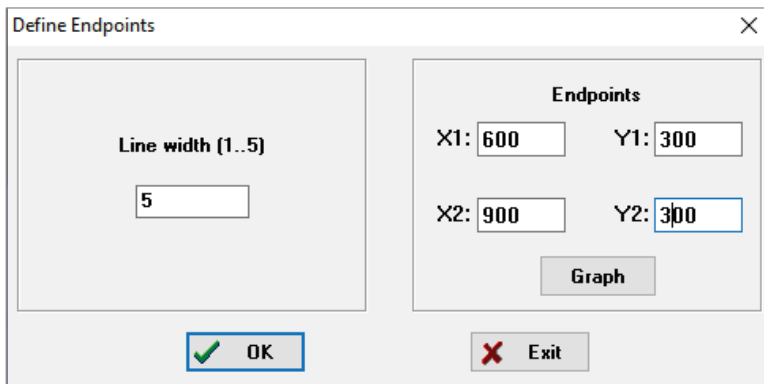

Upon clicking **Define Endpoints** in the Transect dropdown menu, a dialog window is opened in which the user may choose one out of 5 **line widths** and define the **coordinates** of the two endpoints of the line segment. With increasing line width, the signal to noise ratio of the Transect plot is increased. The coordinates of endpoint 1 (X1, Y1) and endpoint 2 (X2, Y2) can be manually entered into the corresponding boxes. Then upon clicking OK the Transect profile is displayed. If the coordinates of the envisaged endpoints are not known, which is normally the case, the endpoints can also be defined graphically. When the **Graph button** is clicked, in the Image window a line segment

appears, one of the endpoints of which temporarily is fixed, while the other one can be freely moved with the cursor (marked by a cross) until it is fixed by a left mouse click. Now the other end is marked by the cursor and can be freely moved to the second endpoint position, which can be fixed by another left mouse click. Then automatically the Transect profile is calculated and displayed in a separate window.

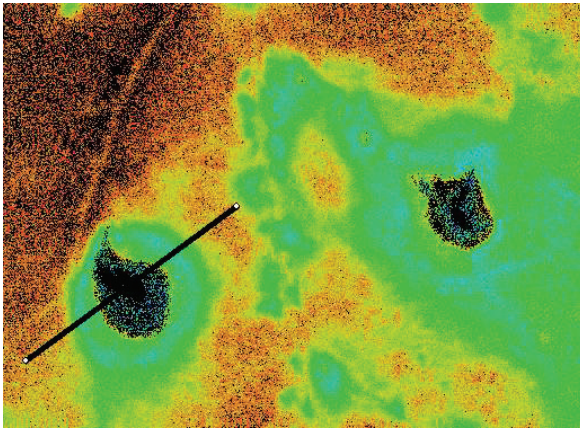

Fig. 37 Transect line through a Yield image

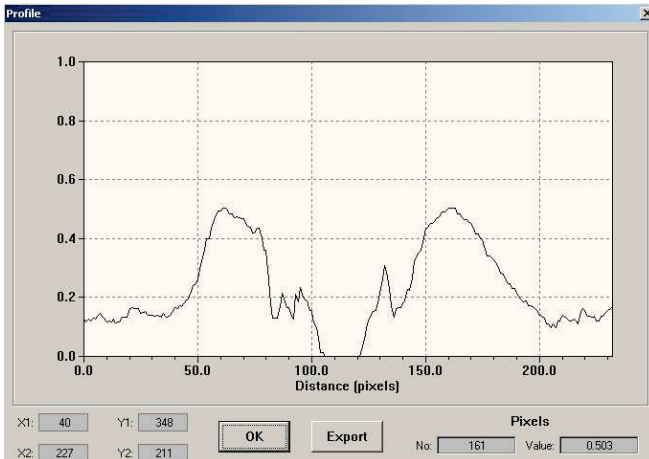

Fig. 38 Transect plot of the line shown in Fig. 37

The Pixel values of the selected Image parameter are plotted as a function of Pixel number along the line segment. In the lower left corner of the window the **x-y coordinates** of the two endpoints of the transecting line segment are displayed. They may serve for reproducing an identical transect later. In the lower right corner the **Pixel value** and **Pixel number** of the point marked by the cursor are displayed. When the **Export button** is clicked, a list of all Pixel value/Pixel number couples is saved in the form of the file **profile.csv** into the **Data directory** of the applied Measuring-Head, from where it can be imported into a spread sheet program, like **Excel**. If Excel is installed on the PC, the export.csv file is in most cases automatically opened in Excel. Please note that the export.csv file will be overwritten with the following data export. To avoid this, it should be renamed.

8 Troubleshooting

8.1 Error Network Settings

It can happen that a computer on which the ImagingWin software is to be installed for the first time brings an error message about "Network settings". In this case, check the following system settings:



- Search for the "Settings" app:
- Find the "Network & Sharing Center" and identify the network connection the Imaging system is using (normally it is shown as "Ethernet" – the Imaging device must be connected and switched on.
- Click on the field "Change adapter settings" and a new window opens:

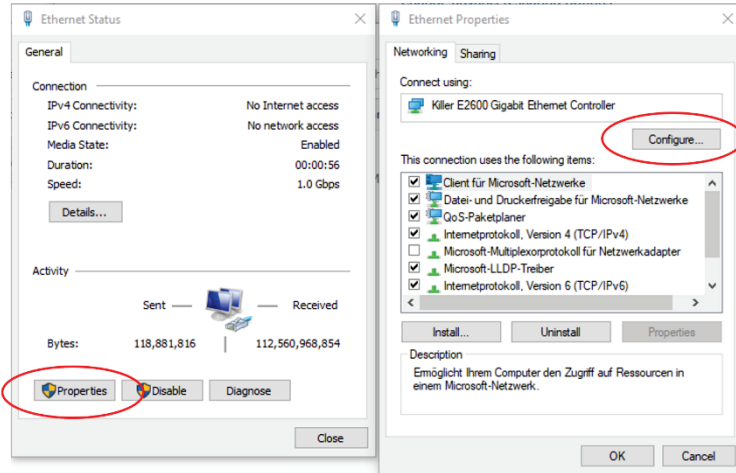

Open the "Properties" window and click on "Configure" and select the tab "Advanced".

Here you can find a list of many different network properties. The details vary, depending on the network hardware.

- The following properties must be checked and adjusted if necessary:

Property	Value
Jumbo Packet	9014 Bytes
Energy Efficient Ethernet	off
Packet Priority & VLAN	disabled
Transmit buffer	1024 or more
Wait for Link	off

8.2 No Connection with the Computer

It may happen that divers interfere with each other so that after the installation of a new software the camera driver of the HEXAGON-IMAGING-PAM got lost and no connection is possible. For these events the easiest way to reconnect it is to reinstall the entire ImagingWinGigE software. It is also a good idea to check the Walz website to see if a newer version of the software is available.

9 List of key commands

The IMAGING-PAM normally is operated via the ImagingWin user interface by cursor and mouse click operations. However, also some key commands are possible which in certain instances may be used as shortcuts. All key commands require simultaneous pressing of the Ctrl-key:

Ctrl A	Actinic Light on/off
Ctrl I	Open Image window
Ctrl K	Open Kinetics window
Ctrl L	Open Light Curve window
Ctrl M	Fo, Fm-determination
Ctrl Q	Switch between Measuring Light Frequency 1 and 8
Ctrl R	Open Report window
Ctrl S	Open Settings window
Ctrl V	Switch to Live Video mode
Ctrl Y	Yield determination by Saturation Pulse

10 Technical specifications HEXAGON-PAM

10.1 HEXAGON-PAM

- Design:** 78 LEDs in 6 segments (hexagon) to provide a highly homogeneous sample illumination. Far-red LEDs in two separately controlled circles.
- LEDs:** Powerful Cree high power LEDs: 451 nm, 600 W; actinic light intensity up to 2000 $\mu\text{mol photons m}^{-2} \text{s}^{-1}$; saturation pulses of up to 4100 $\mu\text{mol photons m}^{-2} \text{s}^{-1}$.
- Dimensions:** Maximum dimensions: height 48.5 cm, depth 51.5 cm and width 47 cm.
- Sample options:** Detached leaves, algae (Petri dishes, microwell plates), potted plants, plant trays.
- Camera:** Sony IMX264 CMOS 2/3" Sensor 3.45 x 3.45 pixel size; 8 mm lens for imaging of 1200 x 1000 px in 10-bit color depth.
- Working distance:** 20 cm for 20 x 24 cm image area.
- Light field properties:** Vertical incidence on sample; at standard working distance maximal deviation from mean intensity +/- 7 %.
- Digital zoom:** Standard 2 x 2 pixel binning can be switched unbinned mode giving a 4-fold zoom.
- Safety turn off LEDs:** When the doors of the instrument are opened during an experiment all light

sources with the exception of the measuring light are automatically turned.

- Weight instrument:** 18.3 kg (including camera and bottom plate)
- Operating temperature:** 0 to +45 °C.
- Power supply:** 48 V DC / max. 600 W, weight 5 kg.
- User interface** PC with ImagingWinGigE Software; connection via GigE Ethernet; mouse and keyboard operation; monitor screen display.
- Control computer:** Recommended and available as accessory: Intel NUC mini-PC with Win-10 OS (weight 1.16 kg (including power supply, mounting bracket and cable).
- Display resolution:** Recommended screen display resolution: WQHD with 2560 x 1440 pixels.

10.2 Windows Software ImagingWin

- PC requirements:** Intel CPU 1.7 GHz, 8 GB free RAM, built-in Gigabit Ethernet (GigE), Windows 10 or 11
- Features:** Data display and instrument settings in up to 7 different tabs
- Image: display of 18 different parameters

- Kinetics: light-induced, time dependent changes of fluorescence parameters
- Light Curve: registration of preprogrammed light response curves
- Report: numerical lists of parameter values for selected areas of interest (AOIs)
- Settings: instrument settings

Technical specifications are subject to change without prior notice.

11 Manufacturer's Guarantee

Under this Manufacturer's Guarantee ("Guarantee"), subject to the Conditions and Instructions below, Heinz Walz GmbH, Germany ("Manufacturer"), guarantees (§443 BGB) to the end customer and user ("Customer") that all products supplied by it shall substantially conform in material respects to the Specifications for 24 months from the delivery date (date on invoice). In this Guarantee, "Specifications" means the product's features (as may be amended by Manufacturer from time to time), which are set out under the headings "specifications" and/or "technical specifications" within the product's respective brochure, data sheet, or respective tab on the Manufacturer's website for such product, and which may be included with the documents for the product when delivered. In case of an eligible guarantee claim, this Guarantee entitles the Customer to repair or replacement, at the Manufacturer's option, and this Guarantee does not include any other rights or remedies.

11.1 Conditions

This Guarantee shall not apply to:

- Any defects or damage directly or indirectly caused by or resulting from the use of unauthorized replacement parts and/or service performed by unauthorized personnel.
- Any product supplied by the Heinz Walz GmbH, Germany which has been subjected to misuse, abuse, abnormal use, negligence, alteration or accident.
- Damage caused from improper packaging during shipment or any acts of God.

- Batteries, cables, calibrations, fiberoptics, fuses, gas filters, lamps (halogen, LED), thermocouples, and underwater cables.
- Defects that could reasonably have been detected upon inspection of the product when received by the Customer and not promptly noticed within ten (10) days to Heinz Walz GmbH.
- Submersible parts of the DIVING-PAM or the underwater version of the MONITORING-PAM have been tested to be watertight down to the maximum operating depth indicated in the respective manual. Guarantee shall not apply for diving depths exceeding the maximum operating depth. Further, guarantee shall not apply for damage resulting from improper operation of devices, in particular, the failure to properly seal ports or sockets.

11.2 Instructions

- To obtain guarantee service, please follow the instructions below:
- The Walz Service Information Form available at https://www.walz.com/support/repair_service.html must be completed and returned to Heinz Walz GmbH, Germany.
- The product must be returned to Heinz Walz GmbH, Germany, within 30 days after Heinz Walz GmbH, Germany has received written notice of the defect. Postage, insurance, and/or shipping costs incurred in returning equipment for guarantee service are at customer expense. Duty and taxes are covered by Walz.
- All products being returned for guarantee service must be carefully packed and sent freight prepaid.
- Heinz Walz GmbH, Germany is not responsible or liable for missing components or damage to the unit caused by

handling during shipping. All claims or damage should be directed to the shipping carrier.

11.3 Applicable law

- This Guarantee is governed by German law. Place of jurisdiction is Bamberg, Germany.

14 Index

<hr/>		Autoscale	76
2		aw	86
2x2	66	<hr/>	
<hr/>		<i>B</i>	
<i>A</i>		B/W	96
Abs command	110	base plate	10
absolute intensities	122	Begin of Repetition Block	108
Absorptivity	32	binning	66
Actinic illumination	24	Buffer Memory	70
Actinic Light	43, 90	Buffer-Memory	40
ai	86	<hr/>	
AL	43	<i>C</i>	
AL + Y	44	Call	108
AL box	24	Camera	131
AL check box	90	Camera cable	12
AL command	112	camera driver	15
AL-List	36, 120	Capture	67
analysis	59	Circle	61
Analysis	67	Clock	110
AOI	17, 60, 73	Clock checkbox	45
AOI shape	18	Clock-time	93
AOI transfer	63	Color	96
AOI type	18	Comment File	85
AOI-array	63, 118	Control computer	132
apparent rate of		coordinates	125
photosynthesis	54	Copy Command	106
Area of Interest	17		

correction images	93	Detect by Fo command	113
Create AOI array	118	dimensions	5
Cree high power LEDs	131	Dimensions	131
csv files	86	Disable/Enable Command	107
Ctrl A	130	Display	96
Ctrl I	130	Display parameters	96
Ctrl K	130	display resolution	6
Ctrl L	130	Display resolution	132
Ctrl M	130	downloads	14
Ctrl Q	130	Duration-time	93
Ctrl R	130		
Ctrl S	130		
Ctrl V	130		
Ctrl Y	130		
current fluorescence	47		
Cursor	67		
<hr/>			
<i>D</i>			
Damping	92	Edit	36
dark fluorescence		effective PS II quantum	
parameters	22	yield	50
dark fluorescence yield	48	effective quantum yield	
dark-adaptation	49	(YII)	24
dark-recovery	74	electron transport rate	54
Default	124	End of Repetition Block	109
Default Settings	103	Endpoints	125
Define AOI-array geometry		energy dissipation	24
	118	Ethernet cable	13
Define Zoom	66	ETR	31, 54, 78
Delay-time	93	event marker	77
Delete Command	107	Exit	109, 114
		Expanded Color	67, 97
		export	85
		Export	42
		Export all to CSV File	111
		Export button	127

Export to CSV File	111	Frequency	89
Export to Tiff File	111	Ft 47	
Ext	43	Ft only command	109
Ext command	112	Fv/Fm	23, 38, 49
<hr/>		Fv/Fm-image	23
<i>F</i>		FvFm	109
<hr/>		<hr/>	
F 48		<i>G</i>	
F Factor	90, 100	Gain	91
F value	48	General safety instructions	1
false color code bar	20, 46	Genty	50
Far Red Light	90	gfm	87
ff 87		gfo	87
File	36	GigE	13
Filled	61	Go	41
flower pots	12	Go box	29, 41
Fluorescence Mode	64	Go Speed	29, 41, 98
fluorescence parameters	73	Go-function	98
fluorescence yield	21	Graph button	125
Fm	37, 48	<hr/>	
Fm'	49	<i>H</i>	
Fm'	49	Hirose I/O cable	12
Fm Scaled Color	97	<hr/>	
fmf	87	<i>I</i>	
fmnf	87	icmax	86
Fo	37, 48	illumination steps	82
Fo, Fm	23, 35, 37	image capture and analysis	46, 59
Fo, Fm button	23	Image Correction	93, 95
Fo, Fm-determination	37		
foav	87		
Fo'-determination	57		
FoStr command	110		

Image transformation	96
Image-window	28, 46
IMAG-HEX/PC	6, 13
IMAG-HEX/PH	12
ImagingWin software	33
ImagingWinGigE	13
incident light	24
Ind. Curve	74
Ind.+Rec.	74
Induction Curve	26, 93
Induction Curves	29
Inh.	58
Inh. Ref. AOI	99
Inhibition	58
Insert Command	107
instrument settings	87
Intensity	89
Introduction	3

J

JPEG	29, 42
Jumbo Packet	129

K

Kautsky effect	26
key commands	130
Kinetics	93
Kinetics window	70
Kinetics-window	26

L

Lake model	52
lcp-file	83
Leaf	61
LED currents	120, 121
LED panel	7
LED-Array cable	13
Light Calibration	122, 123
light controls	43
Light Curve	29, 78
Light Curve Parameters	83
light list	13
Light Meter	122
light sources	35
line widths	125
Live Video	64
Load PAR File	110
LS-C	122
LUT	20, 46

M

Manual recording	75
manual system operation	35
marker	77
Maximal PS II quantum	
yield	49
maximum PS II quantum	
yield	23
mean over AOI	38
Mean over AOI	115

Mean Over AOI command	113	<hr/>	<i>O</i>
Measure	28, 39	Open	42
Measure Abs.	32	Open Script File	106
Measure command	110	operating voltage	15
Measuring Light	43, 89	Options	36, 46
Menu Bar	104	Options Menu	114
Message	109	Overload box	65
mf	86	<hr/>	<i>P</i>
mi	86	PAM Image (PIM)-file	37
mifm	87	PAM Image file	41
mifo	87	par file	121
minimal AOI size	61	PAR values	120, 121
Mirror	96	PAR-Absorptivity	32
ML	43	PAR-List	44, 121
ML command	111	Paste Command	107
monitor	6	Paste to Comment Line	109
<hr/>		PC requirements	132
<i>N</i>		photochemical quenching	57, 58
Network Settings	128	photosynthetic parameters	21
New Record	28, 35, 38, 109	Photosynthetically Active Radiation	43
New Script File	106	Photosystem II	3
NIR	64	phytotoxicity	59
NIR intensity	65	PI-curve	31
NIR-remission	32	pim	29
No Connection	129	pixel	127
noise mask	50, 52, 53	Pixel number	127
non-photochemical	55		
NPQ	37, 49, 55		
NPQ/4	25		
NUC-PC	6, 13		

Set Fm Factor command	112	<i>T</i>	
Set Gain command	112		
Set Marker	77	TIFF	29, 42
Set Meas. Freq command	112	Time/10 s	83
Set Meas. Light	112	TimeStep	108
Set Meas. Light command	112	Transect	36, 125
Set Sat. Light command	113	Transfer FoFm	104
Set Sat. Width command	113	Transfer of AOIs	63
Setting up the HEAXGON-		Transmit buffer	129
IMAGING-PAM	10	types of images	47
Settings window	87		
setup file	14	<i>U</i>	
Show AOIs command	114	Ulbricht Sphere	32
si	87	ULM-500	36, 122
Skript commands	106	Undo Delete Command	107
Skript programming	104	update	14
Slow Induction Parameters	93	USB stick	13
Software installation	13	User interface	132
SP	91	User Settings	103
Spacer	109		
Special safety instructions	2	<i>V</i>	
Start Induction Curve	110	View mode	28
Start Light Curve	110	View-mode	39, 40
Starting window	17		
Stern-Volmer	52, 53, 55	<i>W</i>	
Stop Induction command	110	Wait	108
sw	87	Wait for Link	129
		Weight	132
		working distance	94, 115

Working distance	131	Y(NO)	50, 53
WQHD	6	Y(NPQ)	50, 52
		Yield	109
<hr/> <i>X</i>		Yield command	109
		Yield Filter	99
xanthophyll cycle	55	Yield, Y(II)	50
xpim	29, 41		
X-Y	76	<hr/> <i>Z</i>	
x-y coordinates	127		
<hr/> <i>Y</i>		Zoom	66
		Zoom in	66
Y(II)	50, 51		

© Heinz Walz GmbH, 2023

Heinz Walz GmbH • Eichenring 6 • 91090 Effeltrich • Germany
 Phone +49-(0)9133/7765-0 • Fax +49-(0)9133/5395
 E-mail info@walz.com • Internet www.walz.com